

# SERVICE MANUAL

## ULTIMA 65

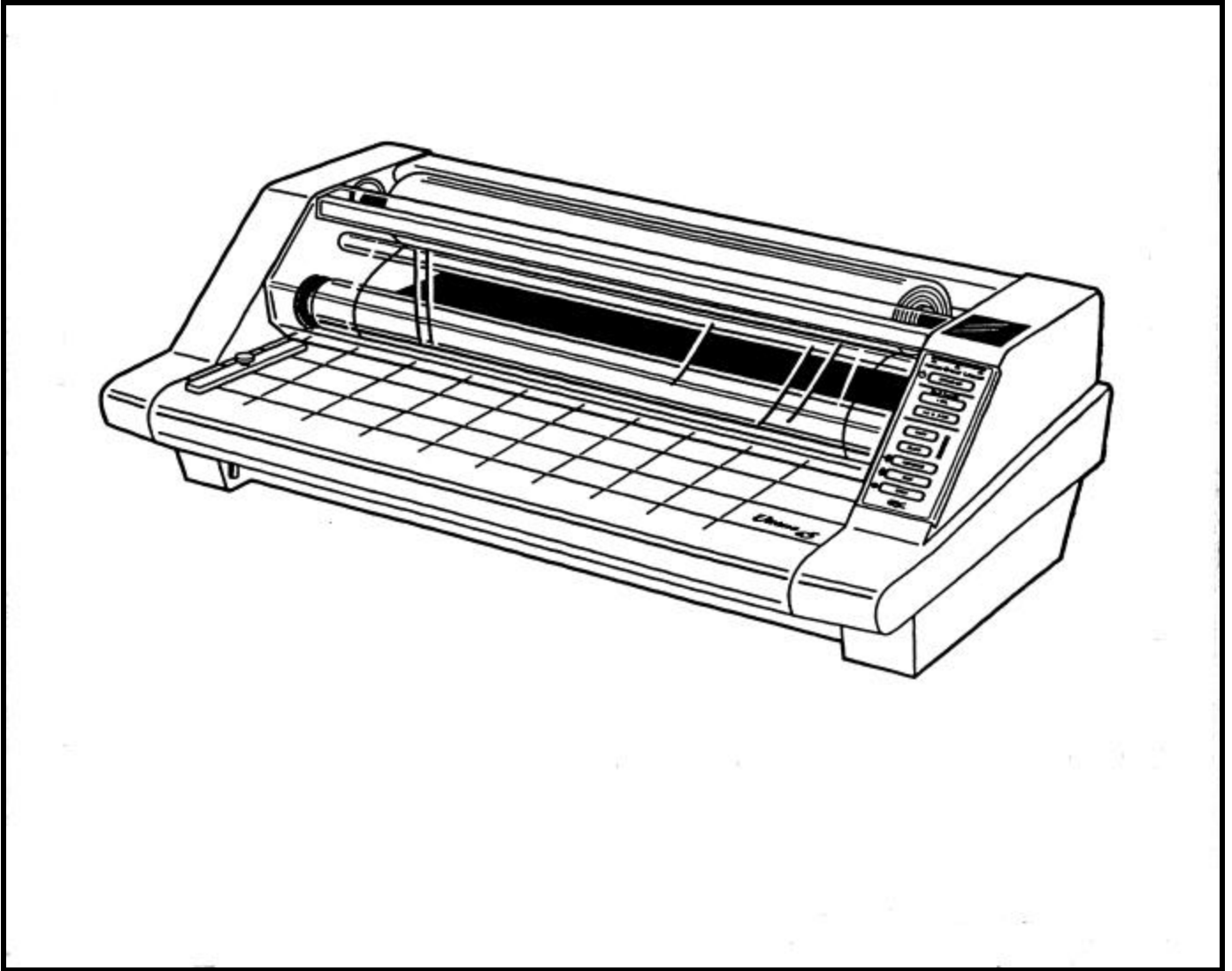

GBC National Service Department

Printed in U.S.A

Part Number 1722768

Assembly Number 1711501

Issued 01/02

Revision: C

© Copyright General Binding Corporation, Northbrook, IL U.S.A

**THIS PAGE INTENTIONALLY LEFT BLANK**

# TABLE OF CONTENTS

	<b>PAGE</b>
<b>1.0 Introduction</b>	<b>1-1</b>
<b>2.0 Specifications</b>	<b>2-1</b>
<b>3.0 Installation</b>	<b>3-1</b>
<b>4.0 Operating Instructions</b>	<b>4-1</b>
<b>5.0 Troubleshooting</b>	<b>5-1</b>
5.1 Theory of Operation	
5.2 Theory of Successful Lamination	
5.3 Electrical system	
5.3.1 Heater Control Circuit	
5.3.2 Motor Control Circuit	
5.4 Mechanical Operation	
5.5 General Troubleshooting	
5.6 Testing Electrical Components	
5.7 Troubleshooting Guide Chart	
5.8 Electrical Wiring Diagram and Schematics	
5.8.1 Ultima 65 Wiring Schematic	
5.8.2 Ultima 65 Wiring Diagram	
<b>6.0 Disassembly / Assembly / Adjustments</b>	<b>6-1</b>
6.1 Film Roll Tension Adjustment	
6.2 Roller Pressure Adjustment	
6.3 Main PCB (PCB1) Calibration Procedure	
6.4 Disassembly/Reassemble Procedures	
<b>7.0 Maintenance</b>	<b>7-1</b>
7.1 External Cleaning	
7.2 Heat Tubes (Rollers) and Pull Rollers	
7.3 Internal Cleaning	
7.4 Inspection	
7.5 Lubrication	

# TABLE OF CONTENTS

	<b>PAGE</b>
<b>8.0 Parts List</b>	
8.1 Ultima 65 Parts List	<b>8-1</b>
8.1.1 Cover Assembly and Film Roll Support Shafts	
8.1.2 Case and Tray Assembly	
8.1.3 Left Side Assembly	
8.1.4 Right Side Assembly	
8.1.5 Frame Assembly	
8.1.6 Roller Assembly	
8.1.7 Control Panel Assembly	
8.1.8 Safety Lever Assembly	
8.1.9 Cutter Assembly	
<b>9.0 Recommended Spare Parts List</b>	<b>9-1</b>
9.1 Recommended Spare Parts List	
9.2 Explanation of Multiplier	
<b>10.0 Additional Information</b>	<b>10-1</b>

# 1.0 INTRODUCTION

Congratulations on your purchase of General Binding Corporation's latest series of laminators. The Ultima 65 series laminator will provide you with high quality lamination and versatility, at an affordable price.

The Ultima 65 will give customers a simple to use laminator that has the ability to laminate GBC's latest film product, the Ultima *1 mil* film. Ultima film provides superior adhesion and higher gloss for better clarity. Ultima film seals at a lower operating temperature, temperature range 200°-275°F (93°-135°C) Ultima 1 mil film is 27" in width, not 25". This feature allows a larger border for customers laminating posters that are 24" in width.

## 2.0 SPECIFICATIONS

### 115 VAC MODEL

### 230 VAC MODEL

<b>Required Power Supply:</b>	120 VAC +/-10% – Two Wire Service Plus Ground 15 Amps, 60 Hz Single Phase	230 VAC +/-5% Two Wire Service Plus Ground 7.8 Amps, 50 Hz Single Phase
<b>Electrical Operating Power:</b>	120 VAC, 15 Amps 1800 Watts, 60 Hz Single Phase	230 VAC, 7.8 Amps 1800 Watts, 50 Hz Single Phase
<b>Dimensions:</b>	32.5 in. (83cm) Wide 21.0 in. (53cm) Long 12.0 in. (31cm) High	
<b>Weight:</b>	85 lb. (39kg)	
<b>Speed:</b>	Variable from 1.5 Feet (45.6cm) to 10 Feet (3m) per minute.	
<b>Warm Up Time:</b>	Approximately 10 Minutes	
<b>Laminating Temperature Range:</b>	200° F (93.4° C) To 290° F (143.4° C)	
<b>Laminating Film Capacity:</b>	Width 27" (68 cm) 1 Mil, 1.5Mil, and 3Mil 1" Poly-In Film, 1" Core Diameter	
<b>Allowable Product Thickness:</b>	Maximum thickness is 1/16" (1.59mm)	
<b>Applications:</b>	Teaching Aides Posters Literature Lightweight materials	
<b>Standards:</b>	UL, CE, CSA listed	

## 3.0 INSTALLATION

1. **Closely inspect the unit prior to opening. All shipping damage should be brought to the immediate attention of the delivering carrier.**
2. Place the laminator on a stable flat surface capable of supporting at least 95 lbs. The surface should be at least 30 inches high to assure comfortable positioning during operation. All four rubber support feet should be positioned completely on the supporting surface. The supporting surface may also be large enough to hold the material to be laminated.
3. The laminator should be positioned to allow exiting film to drop freely to the floor. Accumulation of laminate immediately behind the laminator as it exits the equipment may cause the film to wrap around the pull rollers (wrap-up condition).
4. Avoid locating the laminator near sources of heat or cold. Avoid locating the laminator in the direct path of forced heated or cooled air.
5. Connect the attachment plug provided with the laminator to a suitably grounded outlet only.

**Avoid connecting other equipment to the same branch circuit to which the laminator is connected as this may result in nuisance tripping of circuit breakers or fuses.**

**Please read the operating instructions thoroughly before operating your laminator.**

# **GBC Ultima 65 Laminator**

## *Helpful operating hints for safe, quality lamination*

### **LOCATION OF THE LAMINATOR**

Position your laminator away from drafts that can affect roller temperature.

### **FILM LOADING TIPS**

It is recommended that **LOADING** and **UNLOADING** be performed when the laminator is **COLD**. After removing the old rolls, check the rollers for adhesive residue. Gently rubbing with Scotch Brite pad, then wiping with a damp cloth can easily remove it. Always change the top and bottom film rolls at the same time. Be sure to use the **CORE ADAPTERS** from the **PREVIOUS ROLL**.

Laminating film **MUST UNWIND FROM THE BOTTOM OF THE ROLL** (dull side up) shiny side must be against the rollers. Use the **FILM ALIGNMENT GUIDES** on the film shafts to be certain that the top and bottom rolls are aligned properly. When loading, unwind top and bottom film rolls enough to allow film slack for threading. **REMEMBER TO:** 1) reposition the idler bar in the “J” channel, 2) lower the safety shield, and 3) position the feed tray so the safety latch is engaged.

### **START SLOW**

Turn the power switch **ON**. Machine will default to the **1 MIL/SPEED 5**. If using 1.5 or 3 MIL film, you must press the 1.5/3 MIL button. **SELECT** lamination **SPEED**. Default setting is speed 5. Use the **SPEED GUIDELINES** as a reference or starting point. **LOWER SPEED** for thicker materials, dark colors and heavy ink coverage. **INCREASE SPEED** for thinner materials and lighter colors. **NOTE:** During the initial warm-up period, the roller temperature will rise above the optimum “operating temperature” then fall back. To reduce the effects of excessive heat on your materials when you start, **REDUCE THE SPEED TO SETTING 2 FOR THE FIRST FEW FEET OF OPERATION**. Once the temperature has stabilized, resume running at the “suggested starting” speeds, indicated on the **SPEED GUIDELINES** chart which corresponds to the thickness of the material.

### **READY TO BEGIN**

Begin laminating only after **READY** light is lit. **DO NOT RUN** the laminator when it is **COLD**. Damage to the rollers will result. **PRESS RUN:** While running the laminator, watch the adhesive melt line (the point where the film begins to appear very clear). If the melt line is **AT OR ABOVE** the point where the film and heat roller meet, the selected **SPEED IS OK**. If the melt line shifts **BELOW** the film and heat roller contact point, **DECREASE SPEED** or stop momentarily until the melt line moves up. **DO NOT STOP** machine while documents are passing through the heat rollers.

### **IN THE EVENT OF A WRAP-UP**

Cut the top and bottom film webs. Be sure to **HOLD DOWN** the **REVERSE BUTTON** while pulling the wrapped film from the pull roll.



## IMPORTANT SAFETY INSTRUCTIONS

YOUR SAFETY AS WELL AS THE SAFETY OF OTHERS IS IMPORTANT TO GBC. IN THIS INSTRUCTION MANUAL YOU WILL FIND IMPORTANT SAFETY MESSAGES REGARDING THE PRODUCT. READ THESE MESSAGES CAREFULLY.

**!** THE SAFETY ALERT SYMBOL PRECEDES EACH SAFETY MESSAGE IN THIS INSTRUCTION MANUAL. AND ON THE PRODUCT YOU WILL FIND IMPORTANT SAFETY MESSAGES. READ THESE MESSAGES AND INSTRUCTIONS CAREFULLY. SAVE THESE INSTRUCTIONS FOR LATER USE.

THE FOLLOWING WARNINGS ARE FOUND UPON THIS PRODUCT.



THIS SAFETY MESSAGE MEANS THAT YOU COULD BE SERIOUSLY INJURED OR KILLED IF YOU OPEN THE PRODUCT AND EXPOSE YOURSELF TO HAZARDOUS VOLTAGE.



THIS SAFETY MESSAGE MEANS THAT YOU COULD BE BURNED AND YOUR FINGERS AND HANDS COULD BE TRAPPED AND CRUSHED IN THE HOT ROLLERS. CLOTHING, JEWELRY AND LONG HAIR COULD BE CAUGHT IN THE ROLLERS AND PULL YOU INTO THEM.



THIS SAFETY MESSAGE MEANS THAT YOU COULD CUT YOURSELF IF YOU ARE NOT CAREFUL.

**!** THE SAFETY ALERT SYMBOL PRECEDES EACH SAFETY MESSAGE IN THIS INSTRUCTION MANUAL. THE SYMBOL INDICATES A POTENTIAL PERSONAL SAFETY HAZARD TO YOU OR OTHERS, AS WELL AS PRODUCT OR PROPERTY DAMAGE.

**!** WARNING DO NOT ATTEMPT TO SERVICE OR REPAIR THE ULTIMA 65 LAMINATOR.

**!** WARNING DO NOT CONNECT THE ULTIMA 65 LAMINATOR TO AN ELECTRICAL SUPPLY OR ATTEMPT TO OPERATE THE LAMINATOR UNTIL YOU HAVE COMPLETELY READ THESE INSTRUCTIONS. MAINTAIN THESE INSTRUCTIONS IN A CONVENIENT LOCATION FOR FUTURE REFERENCE.

**!** WARNING TO GUARD AGAINST INJURY, THE FOLLOWING SAFETY PRECAUTIONS MUST BE OBSERVED IN THE INSTALLATION AND USE OF THE LAMINATOR.

### **!** IMPORTANT SAFEGUARDS

#### General

Keep hands, long hair, loose clothing, and articles such as necklaces or ties away from the front of the heat and pull rollers to avoid entanglement and entrapment.

The heat rollers can reach temperatures over 300°F. Avoid contact with the heat rollers during operation or shortly after power has been removed from the laminator.

Keep hands and fingers away from the path of the sharp film cutter blade located at the film exit.

Do not use the laminator for other than its intended purpose.

Do not place the laminator on an unstable cart, stand or table. An unstable surface may cause the laminator to fall resulting in serious bodily injury. Avoid quick stops, excessive force and uneven floor surfaces when moving the laminator on a cart or stand.

Do not defeat or remove electrical and mechanical safety equipment such as interlocks, shields and guards.

Do not insert objects unsuitable for lamination or expose the equipment to liquids.

#### Electrical

The laminator should be connected only to a source of power as indicated in these instructions and on the serial plate located on the rear of the laminator. Contact an electrician should the attachment plug provided with the laminator not match the receptacles at your location.

**!** CAUTION: The receptacle shall be located near the equipment and be easily accessible.

Disconnect the attachment plug from the receptacle to which it is connected and keep the power supply cord in your possession while moving the laminator.

Do not operate the laminator with a damaged power supply cord or attachment plug, upon occurrence of a malfunction, or after the laminator has been damaged. Contact GBC's Technical Service Department or your dealer/distributor for assistance.

#### Service

Perform only the routine maintenance procedures referred to in these instructions.

**!** Do not attempt to service or repair the laminator. Disconnect the plug from the receptacle and contact GBC's Technical Department or your dealer/distributor when one or more of the following has occurred.

- The power supply cord or attachment plug is damaged.
- Liquid has been spilled into the laminator.
- The laminator is malfunctioning after being mishandled.
- The laminator does not operate as described in these instructions.

## INSTALLATION

1. **Shipping damage should be brought to the immediate attention of the delivering carrier.**
2. Place the GBC Ultima 65 on a stable flat surface capable of supporting at least 95 lb. (45 kg). The surface should be at least 30 inches high to assure comfortable positioning during operation. All four rubber support feet should be positioned completely on the supporting surface. The supporting surface may also be large enough to hold the material to be laminated.
3. The laminator should be positioned to allow exiting film to drop freely to the floor. Accumulation of laminate immediately behind the laminator as it exits the equipment may cause the film to wrap around the pull rollers, resulting in a "jammed" condition.
4. Avoid locating the laminator near sources of heat or cold. Avoid locating the laminator in the direct path of forced heated or cooled air.
5. Connect the attachment plug provided with the laminator to a suitably grounded outlet only. **Avoid connecting other equipment to the same branch circuit to which the laminator is connected as this may result in nuisance tripping of circuit breakers or fuses.**

## SPECIFICATIONS

Operating Speed - 1.5 fpm (45.6 cm) to 10 fpm (3m).

Dimensions - 32.5 in. (83 cm) wide x 21 in. (53 cm) long x 12 in. (31 cm) high.

Weight - 85 lb. (39 kg).

Electrical requirements - Refer to the serial plate located on the rear of the laminator for the specific electrical rating applicable to the unit.

Voltage	120V ~ 60Hz	230 ~ 50 Hz
Current	12.5A	7.8 A
Power	1500 W	1800 W

## KNOW YOUR GBC ULTIMA 65 LAMINATOR

**A. POWER SWITCH:** Located at the back right of the machine applies power to the laminator. The "POWER" lamp will illuminate when position marked "I" is pushed. The off position marked "O" removes power from the laminator (Figure 1).

### B. CONTROL PANEL: Figure 2

**POWER LAMP:** Indicates that the laminator is plugged in and the main power switch is in the "ON" (I) position.

 **WAIT LAMP:** Illuminates when you first turn the laminator on and when the temperature of the heat rollers is insufficient for the selected film gauge setting.

 **READY LAMP:** Indicates when the laminator has sufficient heat for the selected film

 **STANDBY BUTTON:** This button illuminates when the laminator goes into the "STANDBY" mode, reducing the temperature. When pressed, it enables the unit to return to the predetermined film gauge setting.

**1 MIL BUTTON:** Selects the heat and speed settings for this gauge film. The laminator automatically defaults to this setting whenever the power switch is activated.

Ultima Film (1 Mil) can be identified by a red stripe in the cardboard core.

**1.5 3 MIL BUTTON:** This button must be pressed to set temperature and speed settings required for these thicker gauge films.

**FAST:** When pressed this button increases the speed of the laminator overriding the preset condition.

**SLOW:** When pressed this button decreases the speed of the laminator overriding the preset condition.

 **REVERSE:** Reverses roller movement to clear jams and wrap-ups.

 **RUN:** Activates rollers for normal operation.

 **STOP:** Stops the movement of the rollers.

**C. SAFETY SHIELD:** Figure 3. Prevents entanglement, entrapment and inadvertent contact with the heat rollers. **The laminator will operate only when the Safety Shield is located in the fully down position. Power to the motor is removed when the shield is raised.**

**D. FEED TABLE:** Figure 3. The Feed Table is used to position items for lamination. **The laminator will operate only when the Feed Table and Feed Table Latch are properly installed.**

**E. TABLE INTERLOCK LATCH:** Figure 3. Used to lock the Feed Table into position and activate an interlock switch. The interlock latch is located on the left underside of the Feed Table. The table cannot be removed without retracting the latch to the right while lifting the table upwards and away from the laminator. **The laminator will not operate when the table is removed and/or the interlock latch is retracted.**

**F. FEED GUIDE:** Figure 3. The Feed Guide permits aligning the item(s) to be laminated and is used to keep longer items straight. The Feed Guide may also be used to feed smaller items side by side by positioning the guide towards the center of the Feed Table and placing smaller items against each side of the Feed Guide as they are being introduced into the nip point of the heat rollers. To position the adjustable guide, loosen the knob on the top of the guide, slide it to the desired position and tighten the knob to secure in place.

**G. HEAT ROLLERS:** Silicone rubber coated steel tubes. Used to heat the laminating film and compress the heated film to the items being laminated. Heat is provided by an internal infrared element. The heat rollers are motor driven for ease of loading new film.

**H. IDLER BAR:** The idler bars, located near each supply roll are, used to direct the film to the heat rollers. The bottom Idler Bar is movable to ease film loading.

**I. PULL ROLLERS:** The pull rollers, located at the back of the laminator, are motor driven. They simultaneously pull the film and improve the quality of the laminated item.

**J. REAR SLITTER:** Used to cut the film web where it exits the rear of the laminator (Figure 1).

**K. CIRCUIT BREAKER:** Electrical safety device, located under the left side cover, can be reset the operator if tripped (Figure 1).



**WARNING:** If the breaker trips a second time after being reset, contact GBC national Service or your dealer/distributor for assistance.

**L. CORE ADAPTERS:** The film shaft holds the supply roll and the adapters with locking collars hold the rolls of film on the shaft, (Figure 4).

**M. FILM WEB:** Laminating film loaded into the machine.



**N. NIP POINT:** The point at which the top and bottom rollers come into contact. The Nip Point of the heat rollers is the place at which the items for lamination are introduced into the laminator.

## OPERATING INSTRUCTIONS

1. Turn the laminator on (I) at the main power switch located at the back of the machine (Figure 1).





**2. CAUTION:** Make sure safety shield and feed tray are in the proper position to operate the unit.

3. The laminator will automatically default to the 1.0 MIL setting. If you are using 1.5 or 3.0 MIL film you must manually press the **1.5 3.0 MIL** button. The laminator will set the speed and temperature for the respective film and 20 lb. bond paper (copier paper). If you are laminating heavier stock press **SLOW** to reduce the speed for a quality lamination. If the item is lighter increase the speed by pressing **FAST**. Adjusting the speed control to too high a speed may cause the **WAIT**  lamp to illuminate. You will have to slow the laminator down in order to ensure proper lamination. Refer to the speed Guide Chart, located on the top right side cover or section **SPEED GUIDE AND THE ART OF LAMINATING**, for speed settings on similar material.
4. **Do not begin laminating until the WAIT  lamp goes out and the READY lamp illuminates.** The normal warm-up time is approximately 10 minutes.
5. Position the item(s) to be laminated on the Feed Table.
6. Press **RUN**. The rollers will begin to turn, wait for the heat line to disappear then push the item(s) into the nip point of the heat rollers. Additional items can be laminated without stopping and starting the laminator.
7. Should a jam (wrap up) occur, press **STOP**. Refer to the section **CLEARING A FILM JAM** for specific instructions.
8. Stop the laminator once all of the laminated items completely exit the rear of the machine.



**CAUTION:**  Do not reach over the laminator to operate the film cutter.

9. The Film Cutter may be used to separate the laminated items from the film web. Position the cutter on either side of the laminator, depress the cutter's handle while sliding the cutter across the film web.
10. Allow the laminator to remain powered if it is anticipated that the machine will be used within a short period of

time. If the laminator is left for more than 90 minutes without being used the **STANDBY** button will illuminate. After an additional 30 minutes of non-use the laminator will shut off completely. The **POWER** and **STANDBY**  lamps will remain illuminated. **To reset the unit press the STANDBY  button.**

The attached power cord can be disconnected from the receptacle when the laminator will not be used for long periods of time.

## FEED TABLE REMOVAL

Refer to Figure 3 and follow the procedures to remove the feed table:

1. Lift the safety shield to its full upright position.
2. Slide the Feed Table latch to the right.
3. Lift the table upwards and away from the laminator.

## FILM LOADING & THREADING

Refer to Figure 5 or the film threading diagram on the feed table of the laminator for illustration of properly loaded film.

The top and bottom rolls of laminating film must be of the same width and be present simultaneously. A small amount of adhesive will "squeeze out" during lamination. Hardened adhesive deposits can damage the heat rollers. To avoid any damage rotate the rollers at slowest speed when the **WAIT**  lamp is on. Refer to the section **CARING FOR THE ULTIMA 65 LAMINATOR** for instructions regarding removal of the accumulated adhesive.

Adhesive will deposit on the rollers if:

- Only one roll is used.
- Different widths of rolls are loaded together.
- Either roll is loaded adhesive side against a heat roller.
- One or both rolls of film are allowed to run completely off the cores.





The adhesive side of the film is on the inner side of the web (Figure 5). The shiny side of clear film must contact the heat rollers. The dull side of the film contains the adhesive. Use extreme caution when loading delustered (matte) film as both sides appear dull.

Always change the top and bottom supply rolls at the same time. Near the end of each roll of GBC laminating film is a label stating "Warning-End of Roll." The appearance of this label on either the top or bottom roll requires that new rolls of film be installed as soon as the item presently being laminated completely exits the laminator. Do not introduce any additional items into the laminator when the warning label is visible.

## Method Using Film Threading Card

The following procedure uses the film threading card provided with new rolls of GBC film. The laminator should be cool to the touch before proceeding.

1. Turn the main power switch on. If the laminator is already hot turn the main power switch off (O) and allow the unit to cool, then turn the machine back on (I). Remove feed table.
2. Cut remaining top and bottom film webs between supply rolls and heat rollers. **Be careful not to cut the heat rollers.**



3. Raise the safety shield to its full upright position, pull the top piece of film down.
4. Do not allow remaining film to pass through the laminator if there is any exposed liquefied or tacky adhesive. **Liquefied or tacky adhesive will deposit on the heat rollers if the following procedure is not observed.** Grab hold of the web, top and bottom film, install the feed table under the web. Lower the safety shield and push **SLOW** to speed 3 or less. Push the **Reverse**  and guide the web out the front of the laminator. Make certain no exposed adhesive contacts the heat rollers and the film completely exits the laminator.
5. Press **STOP**  after the sheets have passed through the laminator.
6. Lift the safety shield to the full upright position and remove the feed table.
7. Remove the bottom roll of film by sliding the shaft to the right to release it from the hex shaped brake hub. Loosen locking screw on left retaining collar of film supply shaft, slide collar off. Pull shaft partially out of film tube then push back in to knock out left core adapter. Pull shaft all the way out and rotate tube 180 degrees. Use shaft to knock out remaining core adapter.
8. Slide one core adapter into right side of new roll of film ensuring that the film will unroll properly (from the bottom). Slide the film shaft into the core adapter and tube from the right side. Place the other core adapter on the shaft protruding from the left side then replace retaining collar. Tighten locking screw.
9. Lower the bottom idle bar, (Figure 6).
10. Unroll 2 ft. (61 cm) of film. Push leading edge under and around bottom idler bar. Slide the idler bar back into place and drape film over bottom film roll, (Figure 7). Place the bottom roll of film back on the laminator by sliding the shaft into the round hole of the right side frame and the left side into the hex shaped brake hub.
11. Remove top film supply roll from laminator. Repeat steps 7 and 8 from above ensuring the film will unroll from the bottom after the film supply shaft it is placed back on the laminator.
12. Unroll 2 ft. (61 cm) of film. Drape the film over the top idler bar and completely cover both heat rollers.
13. Slide the feed tray under the bottom film web that is draped over the bottom roll of film. Reinstall feed table so that the bottom film web is resting on the tray, (Figure 8).
14. Slide the threading card between the feed tray and the film web lying on the tray. Gently push into the nip area of the heat rollers. The card should now be guiding both rolls of film into the heat rollers, (Figure 9).
15. Lower safety shield then push **RUN** . Watch the leading edge of the threading card to ensure that it enters the nip area of the heat rollers and is being pulled into the laminator. Push **STOP**  once the threading card has exited the rear of the laminator.

16. Check the film alignment. See section **FILM ALIGNMENT PROCEDURE** for instructions if installed film needs alignment.

 **CAUTION THE FOLLOWING PROCEDURE IS PERFORMED WHILE THE LAMINATOR IS HOT. USE EXTREME CAUTION. AVOID CONTACT WITH THE HEAT ROLLERS.**

#### **Method For Tacking New Film to Existing Film**

The following describes a method for loading film whereby the existing film present on the heat rollers may be used in place of the threading card to draw the new film through the laminator. The adhesive of the existing film must be tacky or liquefied. Leading edges of the new film will be overlapped onto the tacky adhesive of the old film. The existing film and the new film will be pulled through the laminator together.

1. Preheat the laminator. Remove the feed tray.
2. Cut remaining top and bottom film webs between the supply rolls and heat rollers.
3. Raise safety shield to full upright position.
4. Do not allow the adhesive side of the film to contact the heat or pull rollers. Liquefied or tacky adhesive deposited on heat rollers will require the rollers to be cleaned per the section **CARING FOR THE ULTIMA 65 LAMINATOR**.
5. Remove bottom film supply roll from laminator, lower bottom film guide.
6. To load new film on film supply shafts repeat steps 7 and 8 in subsection **Method Using Threading Card**.
7. Unroll enough film from the bottom roll of film to slide under the bottom idler bar and tack to the existing film. Slide the bottom idler bar back into place and replace supply roll shaft.
8. Replace the top supply roll shaft and unroll enough film to tack to the existing top roll of film.
9. Install feed table and lower safety shield.
10. Press **SLOW** for slowest speed setting and press **RUN** .
11. Observe the film being pulled through the laminator to assure that the remaining existing film and the new film are advancing concurrently. Any separation between the films will require stopping the motor immediately and the situation corrected.
12. Press **STOP**  once the newly threaded film is completely exiting the laminator.

#### **FILM ALIGNMENT PROCEDURE**

The film supply shafts of the Ultima 65 Laminator come with pre alignment holes on the right side for 9"(21 cm), 12"(31 cm), 18"(46 cm) and 25"(64 cm) film widths. Loosen the locking screw on the right side retaining collar and move to the corresponding hole to match the width of your roll of film. Tighten the locking screw in the pre drilled hole.

## FILM TENSION ADJUSTMENT



Proper film tension, known as brake tension, is the minimum amount of tension required to eliminate wrinkles in the finished item. The film tension is set at the factory. Periodic adjustments should not be necessary unless other than 1.0 or 1.5 mil GBC film is used or the lamination is curling up or down. Film tension may be checked occasionally to assure that the adjustment is not required.

The film should be taut. A properly adjusted roll of film should not require excessive force to turn by hand. Film tension should be enough to introduce a minor amount of drag as the film unrolls. Insufficient tension causes wrinkles while too much tension causes stretching (necking). Uneven tension between the top and bottom rolls create curl. Too much upper tension creates upward curl while too much bottom tension causes downward curl.

1. To adjust the bottom brake. Push and hold the brake lever, (Figure 11), located on the left side frame by the roll of film. Rotate the roll of film until the lever engages the internal mechanism.
2. Refer to Figure 10 for the proper rotation of the film to increase or decrease the tension.
3. Release the brake lever and check the tension by rotating the roll of film. Resistance should be slight, not forced.
4. To adjust the top brake repeat steps 1 through 3.
5. Laminate some test samples to check for proper tension. Further adjust if necessary.

### CLEARING A FILM JAM (Wrap-up)

Film jams (wrap-up) may occur if the film is loaded on backwards or if the area at which film exits the equipment is blocked. The film, when jammed, wraps around heat or pull rollers. To clear a jam it is necessary to rotate the rollers in the reverse direction. When pressed, **REVERSE**  on the control panel will cause the rollers to go in reverse. To clear a jam:

1. Immediately stop the laminator by pressing **STOP** .
2. Set the speed indicator to 2.
3. Raise the safety shield and remove the feed tray.
4. Cut the top and bottom film webs.
5. Grasp the loose ends of the web, pull straight out, install the feed tray so the web is on top of the tray. Lower the safety shield, press **REVERSE**  and guide the film out of the heat rollers.
6. Once the jam has cleared the heat rollers press **STOP** .
7. Thread the film per section **FILM LOADING & THREADING**.

### SPEED GUIDE AND THE ART OF LAMINATION

**Do not attempt to laminate abrasive or metal objects such as staples, paper clips and glitter as they may damage the heat or pull rollers.**

**Do not force items into the nip area of the heat rollers. An item that is not easily drawn into the laminator by the heat rollers is probably too thick to laminate.**

**Wrinkles may result if an attempt is made to reposition an item once it has been grasped by the heat rollers.**

**Do not stop the laminator before an item has completely exited the pull rollers. Even a momentary stop will cause a mark (heat line) on the laminated item.**

Good, consistent lamination is a result of combining proper heat, tension and dwell time. Dwell time is the amount of time the material to be laminated is compressed between the heat rollers and is control by the speed control. When one of the film gauge buttons is selected the laminator automatically sets the speed and temperature for that film and 20 lb. paper.

As a general rule thicker items and films as well as dark or full ink coverage, need to run at slower speeds because they extract more heat from the rollers at a quicker rate. Setting the speed control at slower settings gives the laminator longer dwell time thus allowing proper lamination of thick items. Thinner items, such as standard copier paper (20 lb. bond) and tissue paper, extract less heat from the rollers and can be run at faster speeds.

The **WAIT**  lamp may illuminate if the speed is set too fast for the material being laminated. Either lower the speed setting or press **STOP**  and wait until the **READY**  lamp illuminates.

Operation of the laminator for more than thirty minutes at a time may necessitate a lower speed setting. It is recommended that during periods of long runs the items being laminated are alternated between thick and thin. **Do not combine thick and thin items at the same time as this will result in a poor edge seal around the thinner material.** If you are unsure that the laminator is set at the proper speed for your item, run a test piece (scrap) of the same or similar material through the laminator. This procedure is recommend because rotating the heat rollers prior to lamination will more evenly distribute the heat. Make speed adjustments as necessary.

The following chart provides general guidelines for proper speed settings to use on certain materials and laminating film combinations. **This chart is only a general guide. Different settings may become necessary as the warm up time, lamination time and materials change.**

Material	SPEED GUIDE		
	Film Thickness		
	1.0 Mil (.0010")	1.5 Mil (.0015")	3.0 Mil (.0030")
Newspaper			
20 lb. Copier Paper	8 - 10	8 - 10	3 - 4
Magazine Stock			
Tissue Stock			
Construction Paper	5	5	1 - 3
Posters			
Index Cards			
File Folders	1 - 3	1 - 3	1 - 2
Poster Boards			

### CARING FOR THE GBC ULTIMA 65 LAMINATOR

GBC offers Cleaning kits as well as Extended Maintenance Agreements.

Contact your local GBC Service Representative or your dealer/distributor additional information.

The only maintenance required by the operator is to periodically clean the heat rollers. The following procedure will help keep the heat rollers free of adhesive that has been deposited along the edge of the laminating film. Proper alignment of the rolls of film reduces the amount of "squeeze out".



**CAUTION: THE FOLLOWING PROCEDURE IS PERFORMED WHILE THE LAMINATOR IS HOT. USE EXTREME CAUTION.**





**WARNING: Do not apply cleaning fluids or solvents to the rollers.**



**WARNING: Do not attempt to laminate adhesives marked "Flammable".**

- NEVER clean rollers with sharp or pointed objects.
- Hardened adhesive deposits on the rollers can cause damage to the rollers. Rotate the rollers at the lowest speed setting on the control panel.
- Do not laminate glitter and/or metallic items. Damage to the rollers may result.

1. Remove the film from the laminator following the procedure outlined in the section FILM LOADING AND THREADING.
2. Preheat the laminator until the **READY**  lamp illuminates.
3. Rub the top and bottom heat rollers with a 3M™ Scotch-Brite™ pad.
4. Install the feed table and lower the shield.
5. Press **RUN**  to rotate the heat rollers to an unclean portion. Press **STOP** . Continue this process until the complete surface of both rollers are clean.
6. Follow the procedure in section FILM LOADING AND THREADING, **Method Using Film Threading Card** to reload the laminator.

**\*NOTE:** Do not use metal scouring pads to clean rollers!

## TROUBLESHOOTING GUIDE

SYMPTOM	POSSIBLE CAUSE	CORRECTIVE ACTION
<ul style="list-style-type: none"> <li>POWER lamp does not illuminate when ON/OFF switch is in the ON "I" position.</li> </ul>	Laminator not connected to electrical supply.	Insert attachment plug into receptacle.
	Circuit breaker open.	Reset circuit breaker.
<ul style="list-style-type: none"> <li>Heat rollers do not turn.</li> </ul>	Safety shield in upright position.	Lower safety shield.
	Feed tray interlock pin not in place.	Slide interlock lever all the way into the left side frame.
<ul style="list-style-type: none"> <li>Laminated items exhibit curling.</li> </ul>	Tension between the top and bottom film roll is unequal.	Adjust tension per section FILM TENSION ADJUSTMENT.
<ul style="list-style-type: none"> <li>Laminated items exhibit wrinkles.</li> </ul>	Tension on top or bottom roll of film is too loose.	Adjust tension per section FILM TENSION ADJUSTMENT.
	Speed setting too slow.	Slightly speed up laminator.
	Bottom film roll may be improperly loaded.	Make sure bottom roll of film is around idler bar.
<ul style="list-style-type: none"> <li>Adhesive deposited on heat rollers.</li> </ul>	Top and bottom film webs not aligned.	Align film webs per section FILM ALIGNMENT PROCEDURE.
	Film improperly loaded.	Adhesive (matte) side of laminate film may be against the heat rollers. Load film per procedure outlined in section FILM LOADED & THREADING.
<ul style="list-style-type: none"> <li>Unsatisfactory adhesion of laminate.</li> </ul>	Speed setting too fast for type of material being laminated.	Lower speed setting by pressing <b>SLOW</b> button to slower speed.
	Insufficient heat.	<b>READY</b> <input type="checkbox"/> lamp must be illuminated.
	Laminate improperly loaded.	Adhesive side of film must be facing away from the heat rollers. Bottom roll of film not threaded behind the idle bar.
	Heat rollers require cleaning.	Clean heat rollers per procedure in section CARING FOR THE GBC ULTIMA 65 LAMINATOR.
	Laminated item unsuitable for adhesion.	Item may be dirty or may have non-porous surface that is extremely difficult to laminate.

### SERVICE AGREEMENT

GBC's Equipment Maintenance Agreement will insure the quality performance and long life built into your laminator.

A service charge for travel time, labor and parts may be incurred for each out of warranty service call. GBC's Equipment Maintenance Agreement decreases these expenses and protects your valuable investment. GBC offers several types of agreements to suit your needs and budget. To contact GBC write to:

GBC NATIONAL SERVICE  
 ONE GBC PLAZA  
 NORTHBROOK, IL 60062  
 1/800-477-3444

ONE GBC PLAZA  
 NORTHBROOK, IL 60062  
 847/272-3700

IN CANADA: GBC NATIONAL SERVICE  
 49 RAILSIDE ROAD  
 DON MILLS, ONTARIO  
 M3A 1B3

49 RAILSIDE ROAD  
 DON MILLS, ONTARIO  
 M3A 1B3

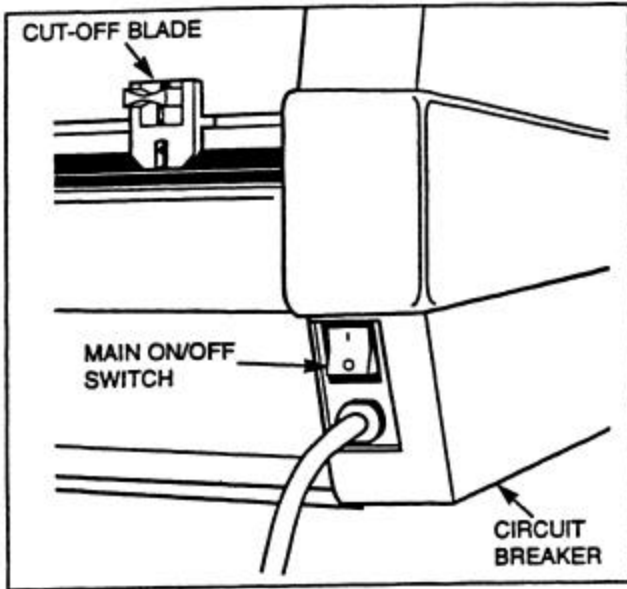

Fig. 1

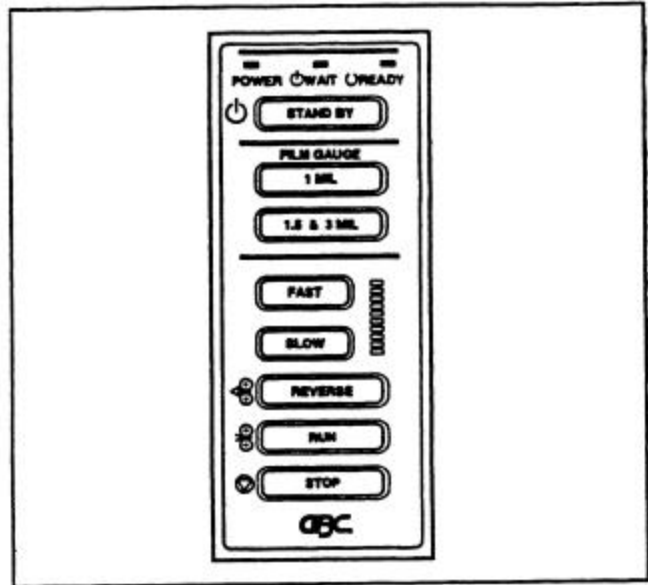

Fig. 2

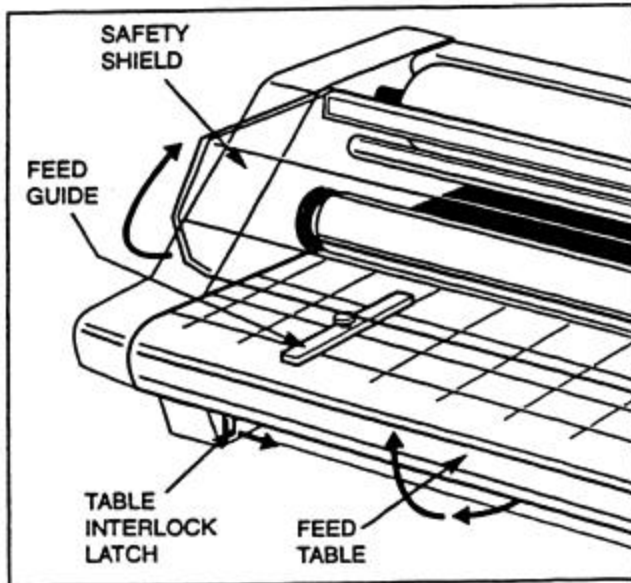

Fig. 3

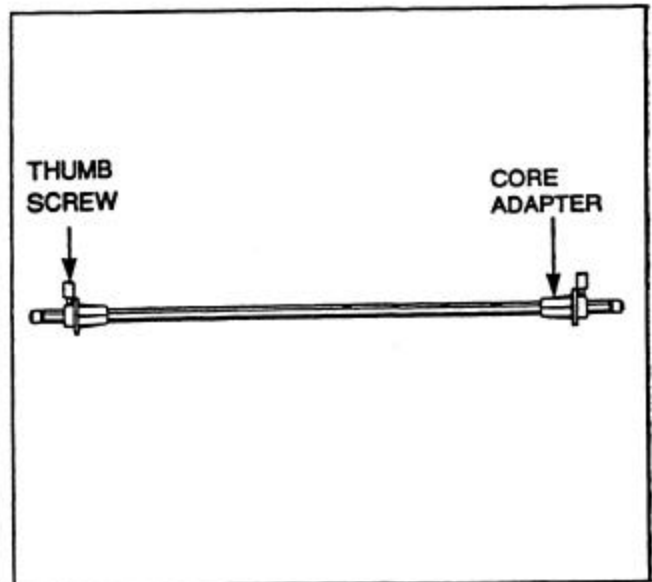

Fig. 4



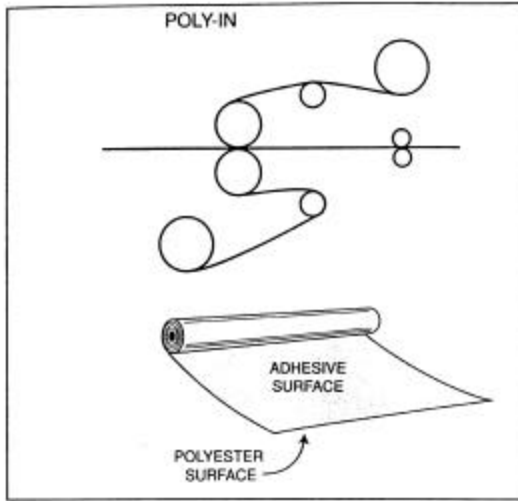

Fig. 5

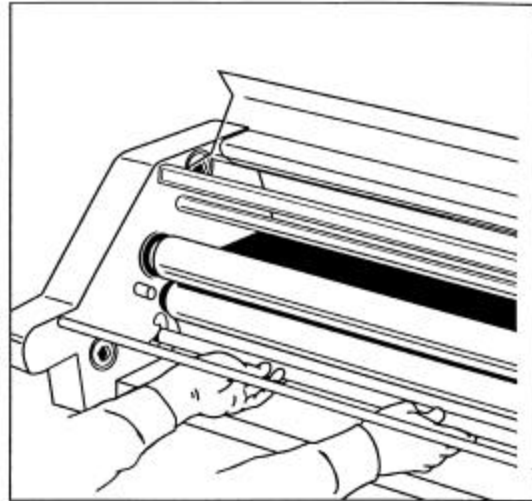

Fig. 6

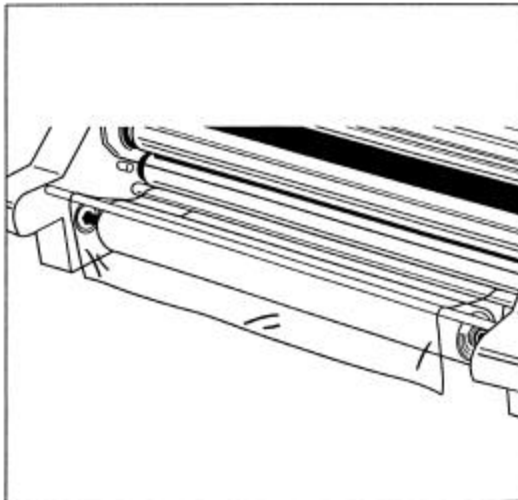

Fig. 7

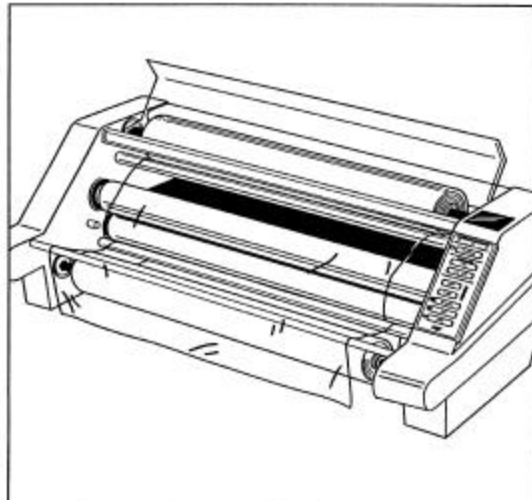

Fig. 8

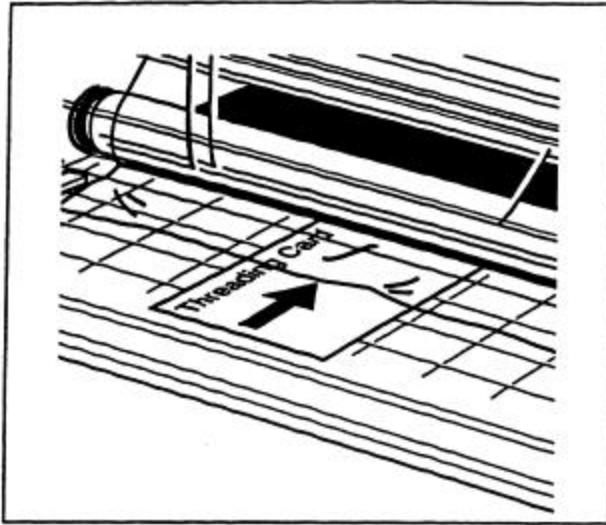

Fig. 9

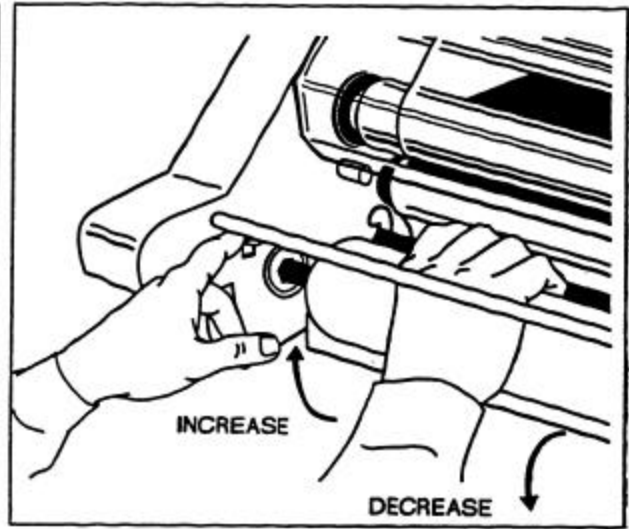

Fig. 10

# 5.0 TROUBLESHOOTING

## 5.1 Theory of Operation

The laminator uses heat, pressure, tension and speed to continuously apply adhesive coated laminating film to both sides of sheet type materials simultaneously. Both electrical and mechanical properties of this laminator are described in this section. Electrical schematics and wiring diagrams are also provided in this section. A basic understanding of the theory of successful lamination is required for all personnel servicing the Ultima 65.

## 5.2 Theory of Successful Lamination

To obtain the ultimate in a successful laminate, three factors should be present:

1. The product to be laminated should be receptive to, and capable of attaining, a good bond with molten polyethylene adhesive.

Most paper products can be laminated with a high degree of integrity. This is because molten polyethylene cements to individual fibers of the paper surface. The rougher the surface texture, the more fibers are exposed to adhesive and the better the bond between adhesive and product. Many substances are applied to paper products, which impair bond between fibers and the molten adhesive. Ink and other printing products affect this bond. While good adhesion occurs between molten adhesive and ink, poor adhesion may exist between ink and its parent paper. Some ink products are heat sensitive and/or lack the ability to be bonded by certain lamination processes. This may require the use of pressure sensitive adhesive (PSA), NAP-LAM II, Vinyl, Premium or HI-TAC type film products.

Some paper and card stocks are coated with silicones, wax or varnish, which inhibit the ability of molten polyethylene to stick tightly to individual paper fibers. In such cases, a superficial bond develops which may be adequate, depending upon intended use of the finished laminate.

Smooth surfaces, especially photographic, metallic, and plastic, are difficult for polyethylene to bond to, since no fibers are exposed for the adhesive to contact. This may require the use of other film products to laminate correctly.

Products containing moisture will not laminate well since the fluid converts to steam, forms bubbles, and impairs lamination.

2. At the moment of lamination, the product - polyethylene interface - both top and bottom, must reach the lamination film's proper operating temperature. Superficial bonds develop at lower temperatures, and the finished laminate may be adequate for its intended use. However, for proper lamination please consult the lamination guide in section 10. Thickness/color of a product bears heavily on the ultimate integrity of the bond, since the thicker/darker a product; the more heat is extracted from the heat rolls. Thicker/darker products may extract heat faster than the machine can put in, and after 20 feet or so, the interfacial temperature may drop below the critical point. Generally speaking, most card stocks whose thickness is on the order of 0.012" thick can be laminated on a continuous basis.

# 5.0 TROUBLESHOOTING

## 5.2 Theory of Successful Lamination (continued)

3. Total encapsulation of product, with a complete film-to-film border, is often recommended to prevent an otherwise successful laminate from splitting within itself.

Total encapsulation of product, of course, prevents splitting from casual abuse of a corner or edge of the laminate, and obviously, moisture vapor or liquid cannot enter to weaken the laminated product.

Flush cutting of laminated product, or even slightly into the product, yields a neat, trim appearance but renders the product sensitive to splitting at the edges and particularly at corners. The split occurs within the product and not at the adhesive product interface. Flush cutting also leaves a paper edge exposed to the atmosphere and any moisture vapor it contains. However, this may be of little consequence unless the laminate is exposed to an actual liquid, where upon the fibers within the product loosen from one another and splitting occurs.

## 5.3 Electrical system

### 5.3.1 Heater Control Circuit

The heater circuit is responsible for the temperature and power regulation of the infrared heater assemblies, working in conjunction with the Main PCB, Control Panel PCB, triac, thermocouple (temperature sensor assembly) and the thermal cutoff (TCO). The Heater Control Circuit is comprised of the following electrical components:

1. **Infrared heater assemblies (IR1 & IR2):** Resistor type heaters that generate heat when activated. **Resistance for the Ultima 65 = 16 ohms (All values +/- 1 ohm).**
2. **Main PCB (PCB1):** Main control board responsible for the control of all electrical components in the machine. SV1 on the PCB, sets the ambient temperature of the machine. SV2 on the PCB, sets the high temperature setting and the ready light on the Control Panel PCB. These 2 potentiometers work in conjunction with the other, when you adjust one the other will also be affected.
3. **Control Panel PCB (PCB2):** Features all the controls and LED indicators for interface with the operator and the laminator.
4. **Triac (TR1):** Voltage applied to the triac is routed through the Main PCB (PCB1) to the Infrared Heaters (IR1 & IR2). This triac can be tested by removing the red and yellow leads from the Main PCB and taking a resistance reading of open. If you get an indication of a short, then the triac has failed closed.
5. **Thermocouple (TSA1):** The temperature sensor provides a heat reference for the Main PCB (PCB1). This sensor should read a short when cold. Ultima 65 has 1 wrap capton tape. These sensors should be soldered and have no air pockets.

# 5.0 TROUBLESHOOTING

## 5.3.1 Heater Control Circuit (Continued)

6. **Thermal cutoff (TCO1):** Provides overheat protection of the heater circuit. Earlier versions have a resettable type TCO and the current production models have a non-resettable type TCO. These TCO's should always read a short and will trip when the TCO reaches a temperature of 248°F (120°C).

**WARNING! NEVER OPERATE THE LAMINATOR WITH THE TCO REMOVED FROM THE HEATER CIRCUIT! DAMAGE TO THE LAMINATOR AND A FIRE HAZARD MAY RESULT!**

## 5.3.2 Motor Control Circuit

Power is supplied to the Motor Control Circuit when the RUN button on the Control Panel PCB (PCB2) is depressed. This circuit is comprised of the Control Panel PCB, Main Control PCB, 3 amp SLO-BLO fuse and the motor.

1. **Control Panel PCB (PCB2):** Features all the controls and LED indicators for interface with the operator and the laminator.
2. **Main PCB (PCB1):** Main control board responsible for the control of all electrical components in the machine. Should supply **output DC voltage to the motor of 7 - 30 VDC:** depending on speed, the faster the speed, the more voltage present.
3. **3 amp SLO-BLO fuse (F1):** Overload protection of the motor.
4. **Motor (M1): 35 VDC. Motor windings 4.5 - 8 ohms.**

## 5.4 Mechanical Operation

The chain driven lower rollers are powered by the drive motor and the Control Panel PCB (PCB2) speed selector. During operation the upper heat roller and upper pull roller are clamped tightly against the respective lower roller by adjustable spring pressure. Both upper heat and pull rollers are driven under pressure by the lower rollers respectfully. The laminating film is compressed by both sets of rollers, however, the primary pressure is applied by the pull rollers and the heat rollers provide only nip pressure. Bronze bushings support the rear rollers and provide smooth even roll during operation. Roller bearings support the front rollers. The two film webs are stretched tight as they leave the supply rolls and enter the nip of the heat rollers. Two adjustable brake assemblies located on the left side frame provide tension. The upper and lower brake assemblies restrict or “drag” the respective supply roll shafts as the shafts revolve.

# 5.0 TROUBLESHOOTING

## 5.5 General Troubleshooting

Malfunction corrections are based on visual observations by the operator and the technician. The cause of malfunctions are isolated by the symptom of the malfunction and noting at which point in the operating cycle the malfunction occurred. Malfunctions that occur during operation can be pinpointed to a defective electrical circuit or to a mechanical part by referring to the "Theory of Operation" in the preceding paragraphs and to the electrical schematic diagrams and electrical wiring diagrams.

**WARNING! POSSIBILITY OF ELECTRICAL SHOCK WHEN TESTING ELECTRONIC COMPONENTS. SERVICE SHOULD BE PERFORMED BY QUALIFIED GBC SERVICE TECHNICIANS ONLY. PLEASE CALL GBC FOR SERVICE 1-800-790-7787.**

## 5.6 Testing Electrical Components

All electrical components can be tested by using a variety of test equipment to check for continuity, resistance, voltage and amperage.

## 5.7 Troubleshooting Guide Chart

The Troubleshooting Guide Chart that follows is arranged in order of the normal operational sequence. When a malfunction occurs, read down the SYMPTOM column until you reach the description for your symptom. Read the corresponding PROBABLE MALFUNCTION, and then perform the recommended procedure in the CORRECTIVE ACTION column. Refer to the wiring diagrams to resolve any wiring difficulties that may occur.

# 5.0 TROUBLESHOOTING

## 5.7 TROUBLESHOOTING GUIDE CHART

SYMPTOM	PROBABLE MALFUNCTION	CORRECTIVE ACTION
No power.	No outlet power. Power cord disconnected. Blown fuse. Tripped circuit breaker. Tripped TCO. Power switch. Bad connections. Bad Main PCB (PCB1).	Check outlet for correct voltage. Connect power cord. Check continuity, replace if needed. Reset circuit breaker. Reset or replace TCO. Replace switch. Inspect for loose connections. Replace board.
Power, no heat.	Bad connections. Infrared heaters bad.  Triac failed. Heat sensor failed. Bad Main PCB (PCB1).	Inspect for loose connections. Check for 16 Ohms, if not replace heaters. Test triac, replace if needed. Test continuity, replace if needed. Replace board.
Not hot enough, or too hot.	Main PCB (PCB1) not calibrated. Triac failed. Heat sensor failed.	Calibrate Main PCB (PCB1) using current calibration procedures. Test triac, replace if needed. Test continuity, replace if needed.
Power, heat, will not run.	Bad connections. Blown motor fuse. Interlock switches not engaged.  Bad motor. Bad Transformer.  Bad Main PCB (PCB1).	Inspect for loose connections. Check continuity, replace if needed. Ensure tray and shield switches are engaged. Check continuity, replace if needed. Check for 3-32 VDC, replace if needed. Test output, replace if needed.
Runs one speed or reverse only.	Bad Main PCB (PCB1). Bad Control Panel PCB (PCB2).	Replace Main (PCB1). Replace Control Panel (PCB2).
Unit does not go to ready.	Main PCB (PCB1) not calibrated. Bad Control Panel PCB (PCB2). Heat sensor failed.	Calibrate Main PCB (PCB1) using current calibration procedures. Replace Control Panel (PCB2). Test continuity, replace if needed.

# 5.0 TROUBLESHOOTING

## 5.7 TROUBLESHOOTING GUIDE CHART (Continued)

<b>SYMPTOM</b>	<b>PROBABLE MALFUNCTION</b>	<b>CORRECTIVE ACTION</b>
Poor lamination quality.	Laminator settings incorrect for product being laminated.	Follow lamination guide in section 10 and the “Theory of Successful Lamination” in section 5.2.
	Incorrect tension.	Follow Film Tension Adjustment in section 4.0 pg 4-5 Operating Instructions.
	Incorrect roller pressure.	Adjust roller pressure.
Consistent wrap-ups, adhesive marks on product.	Dirty rollers.	Follow “Caring For Your Laminator” in section 4.0 Operating Instructions.

**SERVICE SHOULD BE PERFORMED BY QUALIFIED GBC SERVICE TECHNICIANS ONLY.  
PLEASE CALL GBC FOR SERVICE 1-800-790-7787.**



# ULTIMA 65 ELECTRICAL WIRE SCHEMATIC (120VAC)

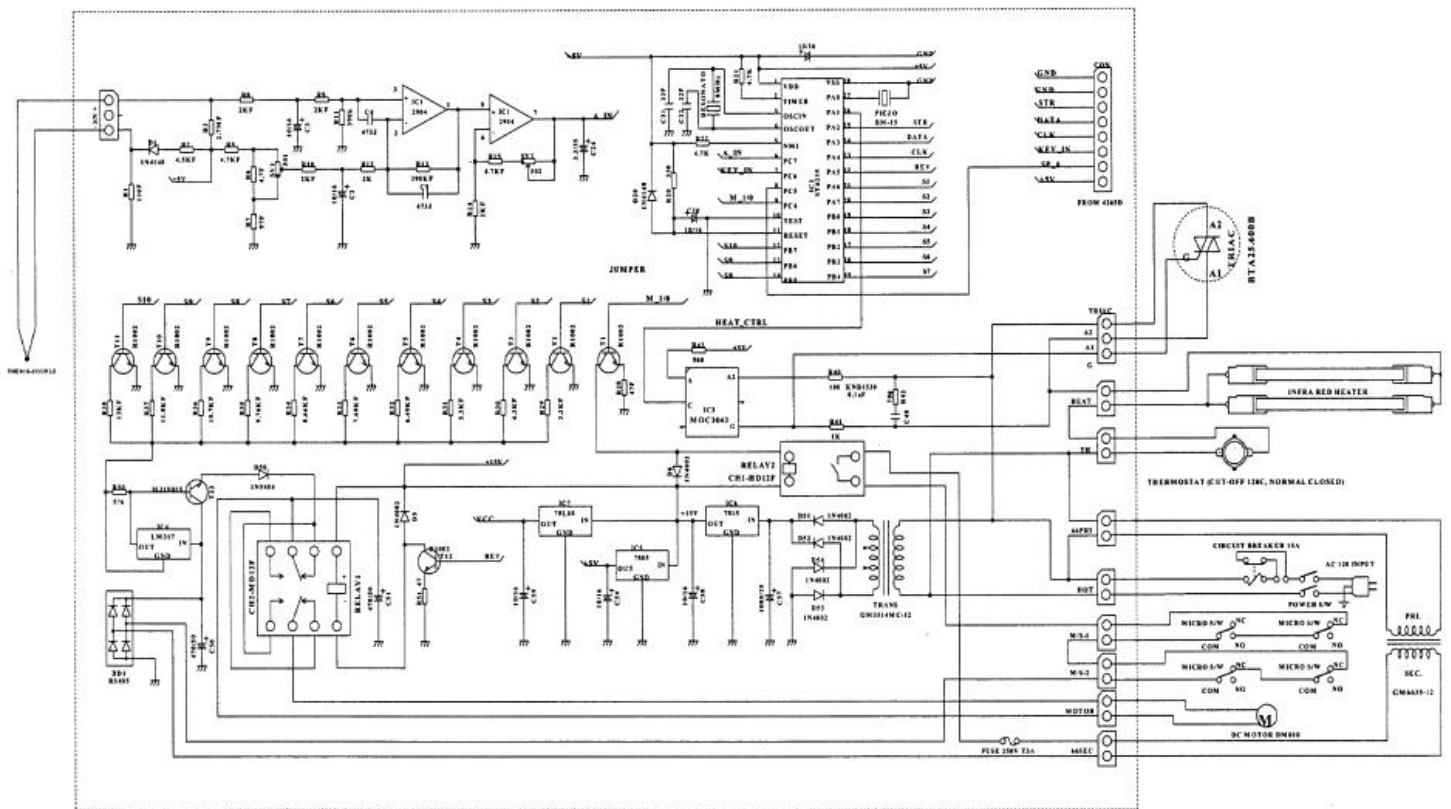



# ULTIMA 65 WIRING DIAGRAM

Only Qualified Technicians Should Take Readings.  
All Ohm Readings Are Out Of Circuit And At Room Temperature.

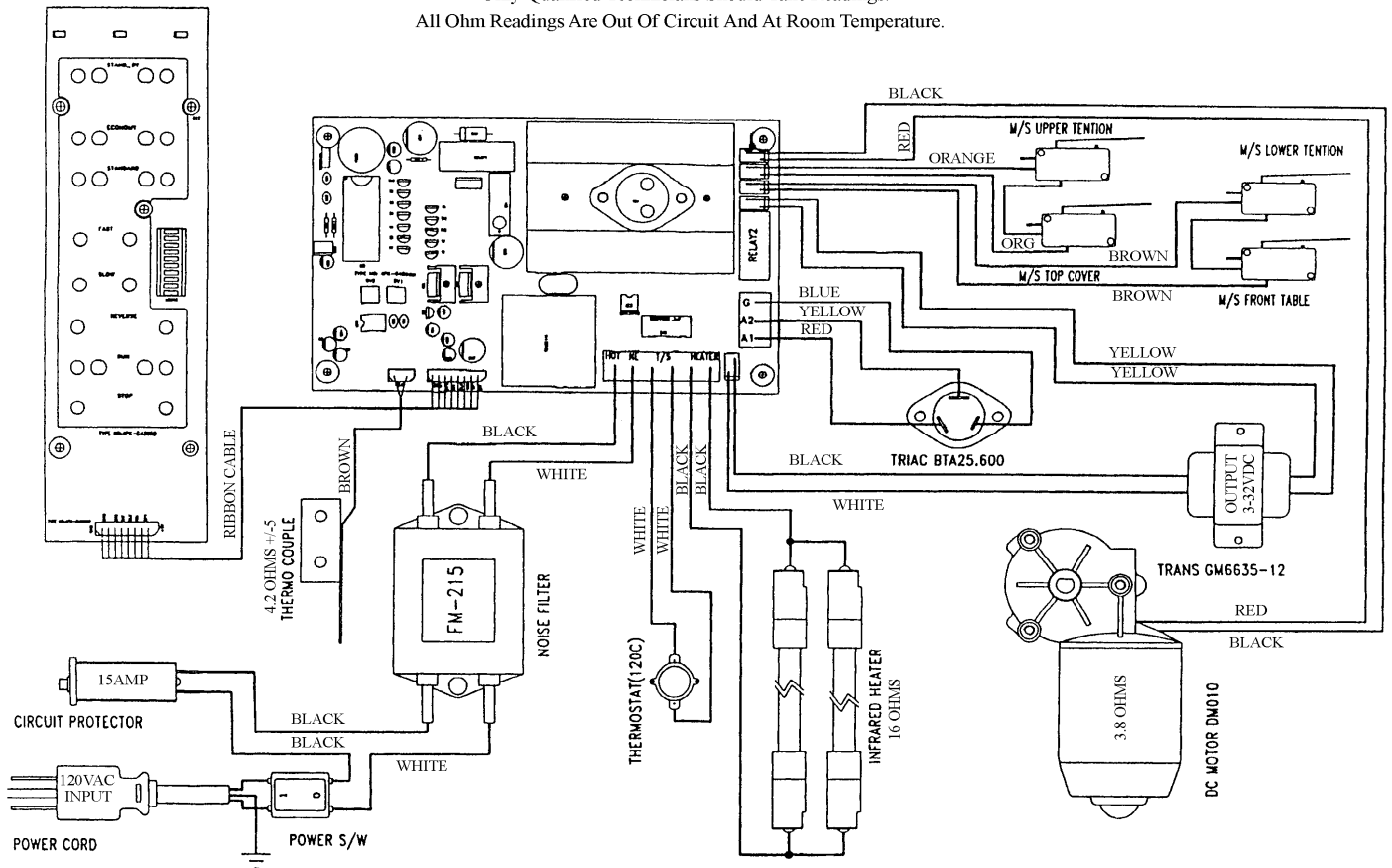

# 6.0 ADJUSTMENTS

## 6.1 Film Roll Adjustment

Proper film tension, known as brake tension, is the minimum amount required to eliminate wrinkles in the finished item. The film tension is set at the factory. Tension adjustments are not necessary if you are using 1.5 or 3-mil GBC film, unless the lamination is curling up or down. Generally, 5 and 10-mil film requires more tension; and, as the film roll becomes smaller, tension increases, requiring more adjustments. Film tension should be checked occasionally to assure the adjustment is correct.

The film should be taut. A properly adjusted roll of film should not require excessive force to turn by hand. Film tension should be enough to introduce a minor amount of drag as the film unrolls. Insufficient tension causes wrinkles, while too much tension causes stretching (necking). Uneven tension between the top and bottom rolls creates curl. **Too much upper tension creates upward curl (smile). Too much lower tension causes downward curl (frown).**

### 6.1.1 Ultima 65 Brake Adjustment Procedure

1. To adjust the bottom brake, push and hold the brake lever located on the left side frame by the roll film. Rotate the roll of film until the lever engages the internal mechanism. Once engaged, rotate the film forward to increase the tension and backwards to decrease the tension.
2. Release the brake lever and check the tension by rotating the roll of film. Resistance should be slight, not forced.
3. To adjust the top brake, repeat steps 1 and 2.
4. Laminate some test samples to check for proper tension. Readjust if necessary.

## 6.2 Roller Pressure Adjustment

The tension on the roller pressure springs determine the pressure between the two top rollers and the associated bottom rollers. Ordinarily, the springs require no adjustment. However, if the springs have been removed or if the tension has been changed, readjustment will be required. Replacement should be considered for those springs that can no longer be adjusted or have little effect. The pressure applied should be enough to enable the rollers to pull the film and product being laminated through, however it should not be so great that it causes marks on the film or product.

## 6.0 ADJUSTMENTS

### 6.2.1 Ultima 65 Roller Pressure Adjustment (Continued)

1. Turn machine off.
2. Remove right and left side covers.
3. Adjust the rear Pull Rollers. The eyebolt on the right and left side should be tightened until only 4-5 threads are showing above the adjusting nut.
4. Adjust the front Heat Tube (Rollers). The Pressure Hex Screw on the right and left side should be flush with the top of the roller bracket.
5. Run a test product and readjust if necessary.

# 6.0 ADJUSTMENTS

## 6.3 Main PCB (PCB1) Calibration Procedure

The Main PCB must be calibrated when replaced. To calibrate the PCB use the calibration fixture GBC P/N 706111164, and follow the calibration procedure outlined below. Calibration must be performed with the new board installed in the machine.

1. The following tools are required to calibrate the Ultima 65.
  - A. Calibration Fixture (GBC P/N# 706111164)
  - B. Amp Meter (Amp Probe) (GBC P/N# 1999105)
  - C. Volt Ohm Meter with spring clips
  - D. Precision Screwdriver
  - E. Infrared Temperature Sensor (GBC P/N# 1722303)
2. **Calibration must be performed when laminator is cold.**
3. Unplug machine from 120V 60Hz outlet.
4. Remove left side cover (facing the front of unit).
5. Disconnect thermal sensor from Main PCB at the (- S/N +) and connect calibration fixture in its place.
6. Set VOM to measure DC voltage.
7. Test points are on the two-pin connector (1+ / 1-) located at the top center area of the PCB, identified as (GND). Locate test points on Main PCB and connect spring clips on leads from VOM to test points.
8. Attach the Amp Probe to the infrared heater wires.
9. Plug the laminator into a suitable 120V 60Hz outlet.
10. Turn power switch to the (On) position.
11. Set control panel on (1.5 / 3 mil setting) with film on the unit and threaded.
12. Select SV1 on the Calibration Fixture. Adjust SV1 potentiometer on the Main PCB until you read 1.15 VDC on the Multimeter.
13. Select SV2 on the Calibration Fixture. Adjust SV2 potentiometer on the Main PCB until you read 3.45 VDC on the Multimeter.

**NOTE: To properly calibrate the Main PCB, confirm the settings are correct by switching between SV1 and SV2 on the calibration fixture and looking at the measured DC voltage on the VOM. This procedure must be done quickly, because the Laminator is heating up and your DC values will change.**

14. Switch the Laminator to the (Off) position. Disconnect meter spring clips, and the Calibration Fixture.

## 6.0 ADJUSTMENTS

### 6.4 Main PCB (PCB1) Calibration Procedure

15. Reconnect the thermal sensor to the Main PCB.
16. Turn Laminator on.
17. Place the beaded thermocouple in the center of the nip rollers (or infrared temperature sensor pointed right at the nip). Adjust SV2 until the ready light illuminates and the nip temperature is 290°F. Do not let the temperature exceed 310°F (this could cause the rollers to blister).
18. When the unit is heating, monitor the Amp Probe for meter deflection. The Amp Probe should deflect to indicate that Laminator is heating, and zero out once the unit has gone to ready.
19. The temperature can be fine tuned while the Laminator is hot by adjusting SV2. Turn SV2 clockwise to decrease heat, and counter clockwise to increase heat. Adjust SV2 in small increments, and then wait at least 5 minutes for the heat to stabilize. Check temperature with infrared temperature sensor or beaded thermocouple.
20. Your Main PCB is now calibrated. Remove Amp Probe, and replace left side cover.

# ALTERNATIVE ULTIMA 65 CALIBRATION

Adjust SV1 to 60 ohms at the points shown below. Do this with the machine cold and the P.C. Board removed from machine.

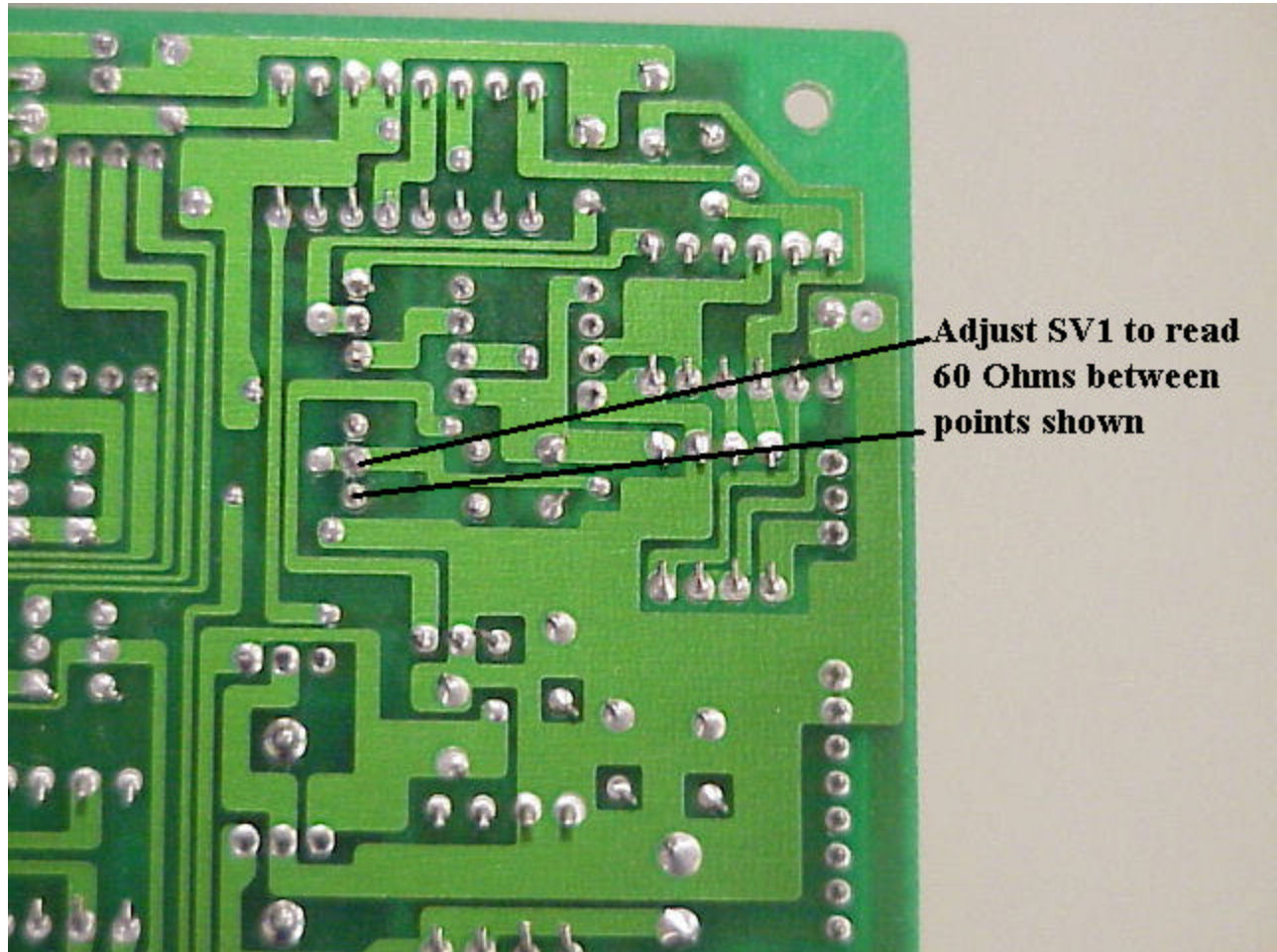

Figure 1



# ALTERNATIVE ULTIMA 65 CALIBRATION CONTINUED

Some P.C. Boards have the trim pot mounted tuner side up. Any reference to clockwise (cw) or counterclockwise (ccw), applies to tuner side up. On a P.C. Board with trim pots mounted tuner side down, the directions of rotation are reverse. See Figure 2.

## TUNER SIDE UP



## TUNER SIDE DOWN

**FIGURE 2**

Set SV2 fully clockwise. You will hear a faint clicking when you pass fully clockwise. Right at the click, turn back one full turn rotation counterclockwise. Install P.C. Board into machine and run it on with an amprobe on the heater circuit wire and a beaded thermocouple in the nip of the heat rollers (or infrared temperature sensor pointed right on the nip). Heat the laminator until the amprobe registers no pulse deflection. Temperature will probably be 225° F to 245° F.

Turn SV2 8 TO 10 full rotations counterclockwise and let temperature increase until it has held and stopped climbing for at least 5 minutes. The amprobe will probably register pulse deflection, showing the circuit is maintaining temperature. Read the nip temperature, at this point, each full rotation counterclockwise will increase the nip by 5° F to 10° F. Or if needed, rotation clockwise will decrease the nip temperature. Do this to reach desired nip temperature.

GBC Lamination Specialist Mike Taylor sent in this Alternative Calibration Procedure.

## 6.0 ADJUSTMENTS

### 6.4 Disassembly/Assembly Procedure

The disassembly of the Ultima 65 is described in the following steps. Use section 8.0 as a reference to help you understand the text. Reassemble in reverse order. **Note: Disconnect the unit from the 120VAC receptacle before performing any disassembly procedures.**

#### 6.4.1 IR Heater and Heater Tube (Roller) Disassembly

1. Remove Feed Table.
2. Remove (4) Phillips Screws from Right Side Plate and remove Right Cover. Remove (4) Phillips Screws from Left Side Plate and remove Left Cover.
3. Remove upper and lower right side Heater Wire Phillips Screws that are attached to the white ceramic ends of the Infrared Heaters.
4. Remove upper and lower left side Heater Wire Phillips Screws that are attached to the white ceramic ends of the Infrared Heaters. The Infrared Heaters are inside of the Heater Tube (Roller).
5. Disconnect the (2) Thermal Cutout (TCO) Wires attached to the TCO by Female Connectors. (Left side of machine).
6. Remove the (2) Phillips Screws for the top and (2) Phillips Screws from the bottom green silicone Heater Holders (right side only).
7. Remove upper and lower glass Infrared Heaters from the right side of the removed green silicone Heater Holders by sliding them out of the Heat Tubes (Rollers). **Note: Use a towel to prevent burns, and to prevent oil from getting on the Infrared Heaters from your hands. Oil on the Heaters can shorten their life expectancy.** Set aside the Infrared Heaters in a safe area to prevent breakage.
8. Remove right Heat Tube (Roller) Pressure Hex Screw and Spring. **Note: When reassembling, refer to 6.2 for Heat Tube (Roller) Pressure Adjustment.**
9. Remove left Heat Tube (Roller) Pressure Hex Screw and Spring. **Note: When reassembling, refer to 6.2 for Heat Tube (Roller) Pressure Adjustment.**
10. Remove Control Panel P.C. Board, by loosening (2) Phillips Screws securing it to the Right Side Frame.
11. Remove (2) Phillips Screws securing upper outer right side Heater Holder Bracket and remove. Remove Snap Ring from upper right Heat Tube (Roller) shaft. Remove inner right side Heater Holder Bracket.
12. Remove (2) Phillips Screws securing lower right side Heater Holder Bracket and remove.
13. Loosen the (2) Set Screws on the Chain Sprocket attached to the lower Heat Tube (Roller) and remove from the Roller shaft.
14. Remove (2) Phillips Screws securing the Thermal cut out (TCO) and upper outer left side Heater Holder Bracket and remove. Remove Snap Ring from upper left Heat Tube (Roller) shaft. Remove inner Heater Holder Bracket.
15. Remove (2) Phillips Screws securing lower left side Heater Holder Bracket and remove. Remove (4) Phillips Screws securing the right side Heat Tube (Roller) bearing housing and remove.
16. Slide Heat Tube (Rollers) out of the open side

## 6.0 ADJUSTMENTS

### 6.4.2 Pull Roller Disassembly

1. Remove Feed Table.
2. Remove (4) Phillips Screws from Right Side Plate and remove Right Cover. Remove (4) Phillips Screws from Left Side Plate and remove Left Cover.
3. Remove (3) Phillips Screws from Right Side Plate securing Upper Rear Cover. Remove (3) Phillips Screws from Left Side Plate securing Upper Rear Cover and remove Upper Rear Cover.
4. Remove Socket Cap Screw and Metal Sleeve from the end of Upper Right Pull Roller. Remove Socket Cap Screw and Metal Sleeve from the Lower Left Pull Roller.
5. Remove Right Hex Nut from Pull Roll Tension Bolt. Lift up Tension Lever to release Pull Roll Tension Bolt. Remove Left Hex Nut from Tension Bolt. Lift up Tension Lever to release Pull Roll Tension Bolt.
6. Remove (3) Phillips Screws from the right Idler Gear Support and remove Support and Idler Gear.
7. Loosen (2) Set Screws on the Upper Right Chain Sprocket attached to the Pull Roller shaft.
8. Loosen (2) Set Screws on the Motor Chain Sprocket attached to the Motor shaft.
9. Remove Upper Right Chain Sprocket and Motor Chain Sprocket.
10. Remove Pull Rollers by tilting one side up and pulling straight out.

# 7.0 Maintenance

## 7.1 External Cleaning

### 7.1.1 External Surfaces

**DISCONNECT POWER PRIOR TO CLEANING EXTERNAL SERVICES.**

Clean external surfaces of the laminator with a soft cloth moistened with a mild solution of detergent (such as dish washing liquid) and warm water. Do not use chemical cleaners or solvents, as these have a harmful effect on painted surfaces. Removal of the films is recommended prior to extensive cleaning. Use detergent solution sparingly to avoid contact with internal electrical parts.

### 7.1.2 Heat and Pull Rollers

Clean both sets of rollers periodically to remove the adhesive extruded from the edges of the film. The adhesive may be removed most easily when the heat rollers are warm. Clean the adhesive from the rollers periodically and after each wrap-up, to insure clear laminations. Use a somewhat abrasive pad such as a 3M Brand No. 96 green commercial scouring pad (greenie). Cleaning kits are available (see sections 8.1.10 and 8.2.12 for part numbers).

**DO NOT CLEAN THESE ROLLERS WITH ANY LIQUIDS OR HARSH ABRASIVES.**

## 7.2 Internal Cleaning

No periodic internal cleaning is required. However, when the side covers have been removed for corrective maintenance, wipe away any dust that may have collected on lubricated parts with a soft cloth, leaving as much lubricant as possible. Do not use any solvent or other cleaning agent since these would tend to dilute or wash away the lubricant from parts where it is needed. Use a small brush to remove dust from non-lubricated parts such as wiring, switches, motor and structural parts.

## 7.3 Inspection

Whenever the side plates have been removed for corrective maintenance, inspect for defects such as loose screws or nuts, abraded wire insulation, loose terminals, and binding of mechanical parts. Correct any defects before returning the laminator to service.

## 7.4 Lubrication

No periodic lubrication is required. However, when parts have to be replaced, lubrication may be required at reassembly.

## 8.0 PARTS LISTS

All parts in each illustration are keyed with an index number for reference to the respective part number, part name, and quantity in the parts list.

When ordering service parts, always include the following information:

1. Machine Model Number
2. Machine Serial Number
3. Part Number
4. Part Name
5. Quantity Required

**Note: The Service Parts Department does not stock all hardware; to avoid delay, standard hardware shown in the parts list should be purchased locally whenever possible.**

# 8.1.1 COVER ASSY. AND FILM ROLL SUPPORT

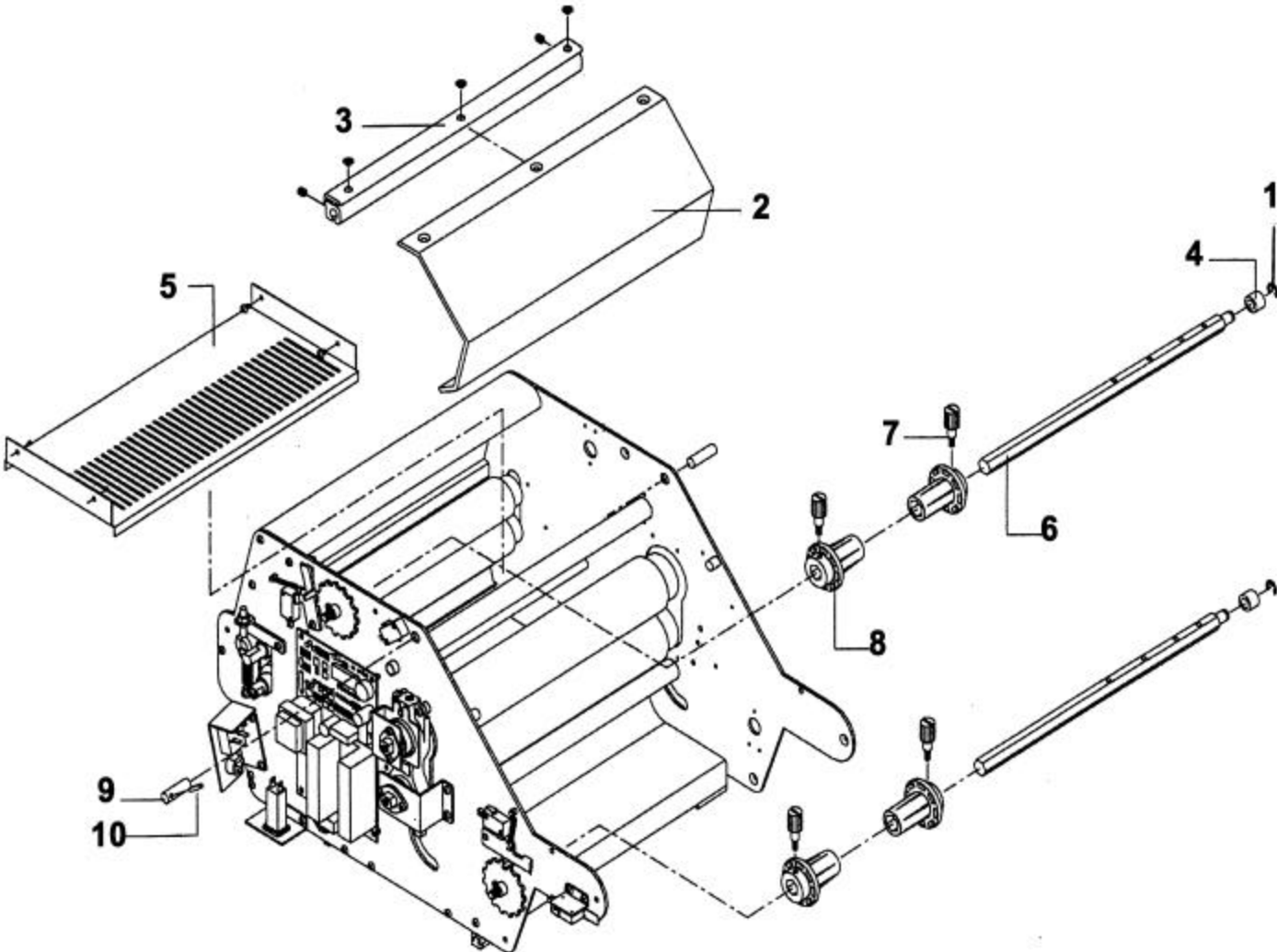

## 8.1.1 COVER ASSY. AND FILM ROLL SUPPORT

<b>ITEM</b>	<b>GBC #</b>	<b>GMP #</b>	<b>DESCRIPTION</b>	<b>QTY</b>
1	1712109	<b>701090705</b>	RETAINING RING	2
2	1711620	<b>601230453</b>	ROLLER COVER	1
3	1711621	<b>603030611</b>	TAKING BAR FOR ROLL COVER	1
4	1711629	<b>613030306</b>	BUSHING	2
5	1711622	<b>601220131</b>	FILM GUIDE SCREEN/UPPER	1
6	1711627	<b>613030211</b>	HEX FILM SHAFT	2
7	1720571	<b>613030527</b>	THUMB SCREW	4
8	1711570	<b>604037021</b>	1" CORE ADAPTER	4
9	1711623	<b>603030612</b>	CENTER PIN FOR ROLL COVER	1
10	1711624	<b>1929222</b>	ROLL PIN	1

**(USE GMP PART NUMBERS WHEN ORDERING PARTS)**

## 8.1.2 CASE AND TRAY ASSEMBLY

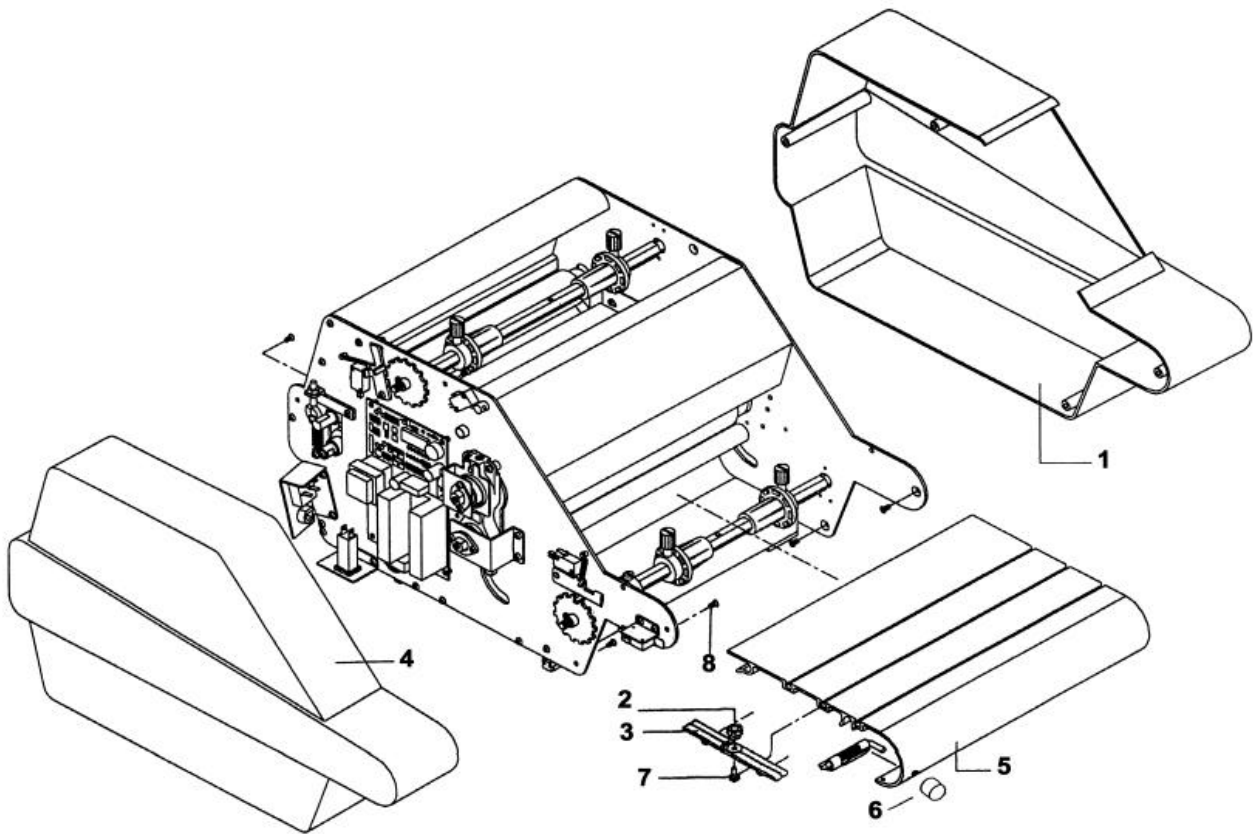



## 8.1.2 CASE AND TRAY ASSEMBLY

<b>ITEM</b>	<b>GBC#</b>	<b>GMP#</b>	<b>DESCRIPTION</b>	<b>QTY</b>
1	1711658	<b>604022002</b>	RIGHT SIDE COVER	1
2	1720584	<b>604022032</b>	FIXING KNOB FOR PAPER GUIDE	1
3	1720583	<b>604022031</b>	PAPER GUIDE	1
4	1711657	<b>604022001</b>	LEFT SIDE COVER	1
5	1711634	<b>604036021</b>	FRONT TABLE	1
6	1711633	<b>613030614</b>	LEVER CAP FOR FRONT TABLE	1
7	1712263	<b>701108133</b>	SCREW FOR PAPER GUIDE	1
8	1711568	<b>613030541</b>	FRONT TABLE SUPPORTS	2
9	N/A	<b>803040370</b>	SPEED GUIDELINES LABEL ( <b>Not Shown</b> )	1
10	1712122	<b>701104504</b>	COVER SCREWS ( <b>Not Shown</b> )	8

**(USE GMP PART NUMBERS WHEN ORDER PARTS)**

### 8.1.3 LEFT SIDE ASSEMBLY

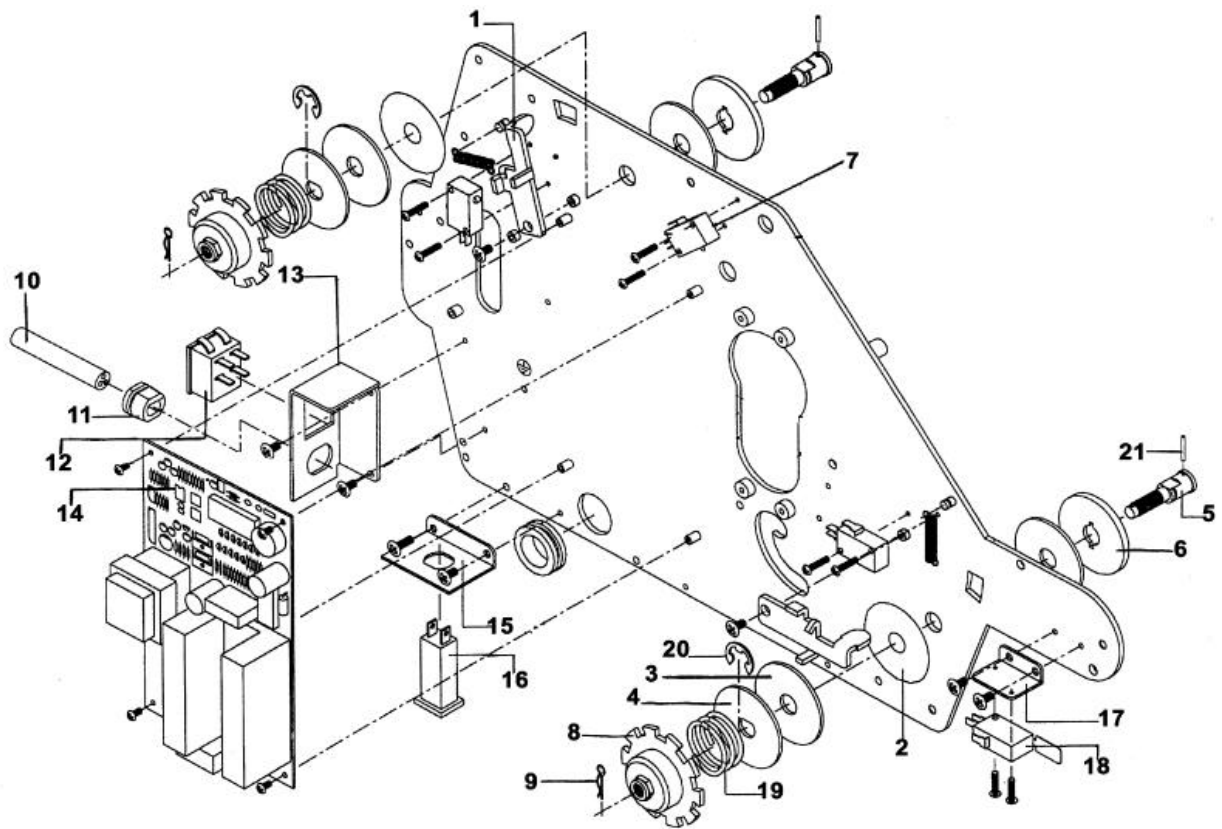

8-5

### 8.1.3 LEFT SIDE ASSEMBLY

ITEM	GBC#	GMP#	DESCRIPTION	QTY
1	1711592	601310505	FILM TENSION LEVER	2
2	1712140	703070101	BRAKE PAD	4
3	1711577	703070111	TENSION PLATE FRICTION DISC	2
4	1720546	601230702	FIBER TENSION PLATE	2
5	1711637	603030537	ADJUSTMENT BOLT FOR FILM TENSION	2
6	1711635	601230713	BRAKE HUB	2
7	1711593	704090414	MICRO SWITCH (FILM ADJUSTMENT)	2
8	1711643	601310512	TENSION ADJUSTMENT PLATE	2
9	1711644	701091102	SPRING PIN	2
10	1711580	704030316	POWER CORD (USA)	1
10	1711585	704030703	POWER CORD (JAPAN)	1
10	1711581	704030416	POWER CORD (UK)	1
10	1711583	704031310	POWER CORD (AUST)	1
11	1711584	704140403	STRAIN RELIEF	1
12	1712650	704090102	POWER SWITCH	1
13	1711586	601310506	POWER PANEL	1
14	1711650	706011116	MAIN PCB (115V)	1
14	1711653	706011112	MAIN PCB (230V)	1
15	1711589	601310507	BRACKET (CIRCUIT BREAKER)	1
16	1711588	704091031	CIRCUIT BREAKER, 15 AMP	1
17	1711594	601310508	MICRO SWITCH BRACKET	1
18	1711595	704090415	MICRO SWITCH, FEED TABLE	1
19	1711608	701110312	BRAKE SPRING WASHER	2
20	N/A	701090706	RETAINING RING	2
21	N/A	701090832	ROLL PIN	2

(USE GMP PART NUMBERS WHEN ORDERING PARTS)

### 8.1.4 RIGHT SIDE ASSEMBLY

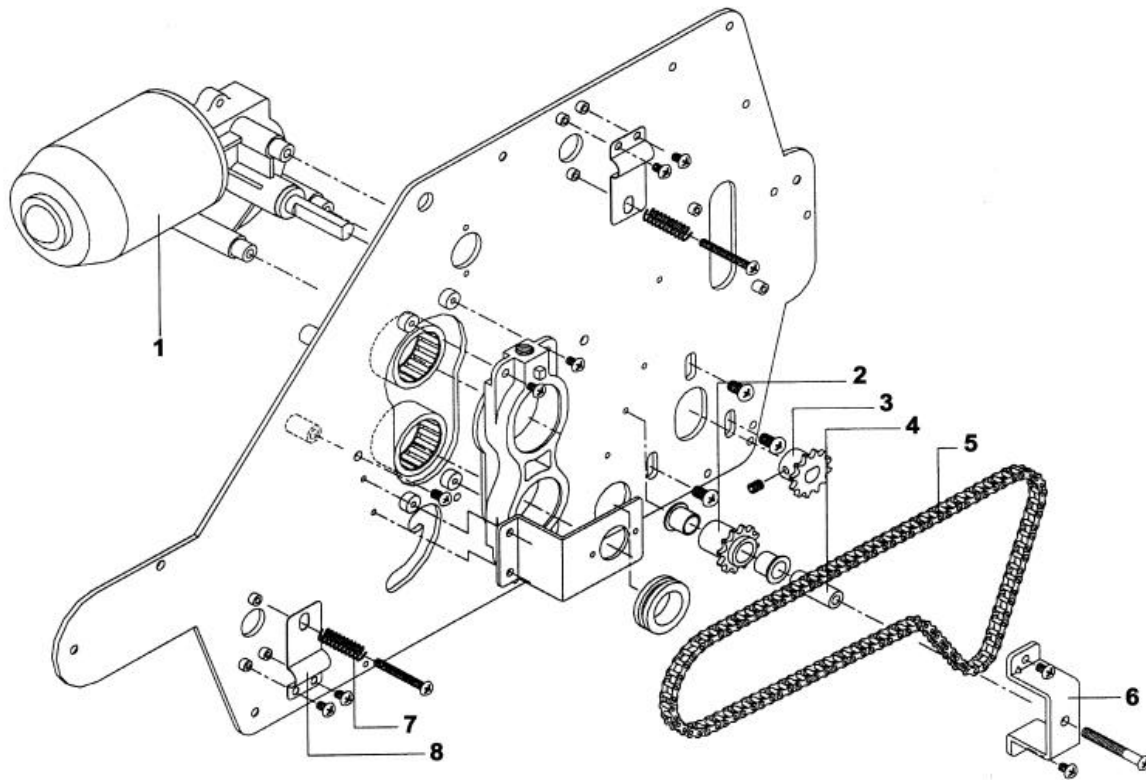

## 8.1.4 RIGHT SIDE ASSEMBLY

<b>ITEM</b>	<b>GBC#</b>	<b>GMP#</b>	<b>DESCRIPTION</b>	<b>QTY</b>
1	1720524	<b>609020200</b>	DC MOTOR	1
2	1711571	<b>701080266</b>	STEEL SPROCKET, 12T * F12	1
3	1711572	<b>701080265</b>	STEEL SPROCKET, 12T * F10	1
4	1711573	<b>613030540</b>	CENTER PIN FOR IDLER GEAR	1
5	1711574	<b>701070150</b>	CHAIN	1
6	1711575	<b>601310504</b>	IDLE GEAR SUPPORT	1
7	1720608	<b>701090158</b>	COIL SPRING (TENSION PLATE)	2
8	1712549	<b>601230802</b>	TENSION PLATE FOR MANDREL	2
	1970104	<b>1970104</b>	(NOT SHOWN) 3A SLO-BLO MINI FUSE ( <b>PCB</b> )	1
	1970120	<b>1970120</b>	(NOT SHOWN) 3A SLO-BLO REGULAR FUSE ( <b>IN-LINE</b> )	1

(USE GMP PART NUMBERS WHEN ORDERING PARTS)

### 8.1.5 FRAME ASSEMBLY

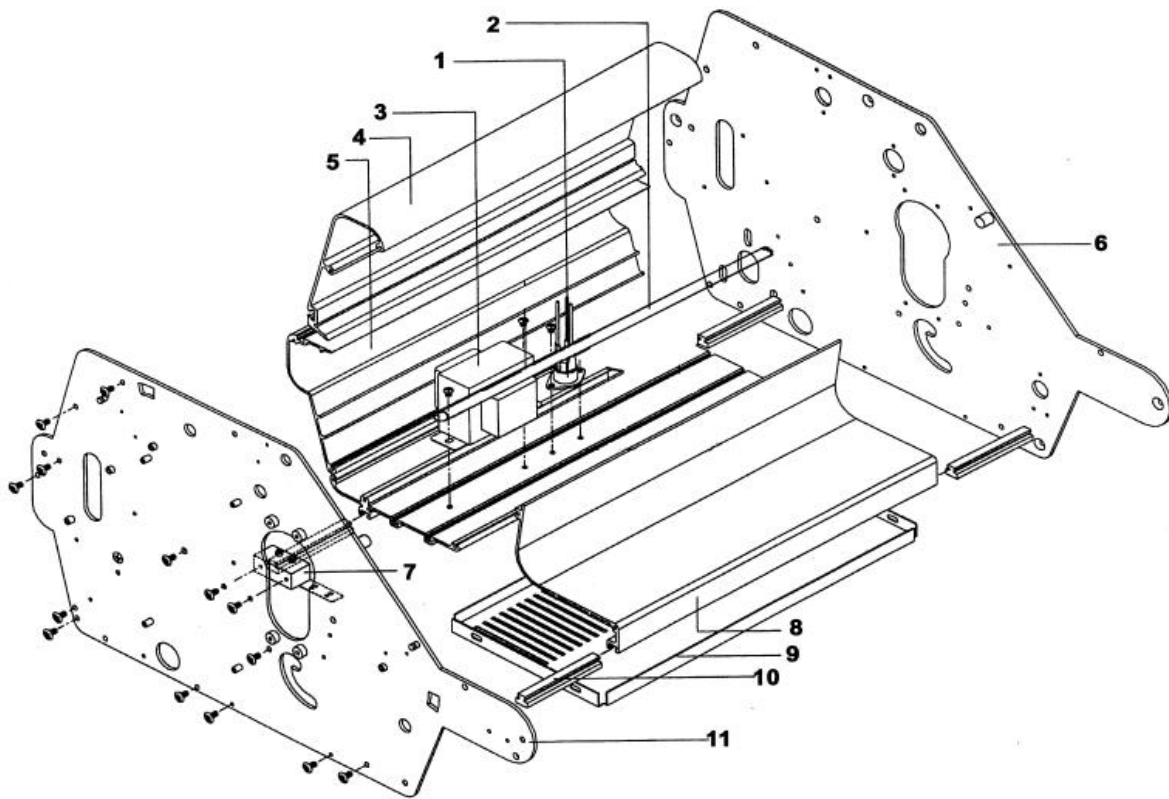

8-9

## 8.1.5 FRAME ASSEMBLY

<b>ITEM</b>	<b>GBC#</b>	<b>GMP#</b>	<b>DESCRIPTION</b>	<b>QTY</b>
1	1711554	<b>07050703</b>	TRIAC	1
2	1711555	<b>603030151</b>	SUPPORT BAR	1
3	1712594	<b>610010206</b>	TRANSFORMER, (OUTPUT 3-32 VDC)	1
3	1712595	<b>610010207</b>	TRANSFORMER ( <b>EUROPE</b> )	1
3	1711558	<b>610010209</b>	TRANSFORMER ( <b>UK</b> )	1
4	1711561	<b>601230451</b>	UPPER REAR COVER	1
5	1711562	<b>601230452</b>	LOWER REAR COVER	1
6	1711560	<b>601230216</b>	RIGHT SIDE PLATE	1
7	1711652	<b>706040202</b>	HEAT SENSOR (THERMO-COUPLE)	1
8	1711563	<b>601230111</b>	FRONT BASE PLATE	1
9	1711564	<b>601220132</b>	LOWER FILM GUIDE SCREEN	1
10	1711565	<b>703010111</b>	RUBBER FOOT	4
11	1711559	<b>601230215</b>	LEFT SIDE PLATE	1

(USE GMP PART NUMBERS WHEN ORDERING PARTS)





## 8.1.6 ROLLER ASSEMBLY

ITEM#	GBC #	GMP #	DESCRIPTION	QTY
1	1711617	701080233	SPROCKET	1
2	1711616	601310510	RIGHT TENSION LEVER FOR PULL ROLLERS	1
3	1712049	601230804	HOUSING FOR DRY BEARING	1
4	1711614	603030161	UPPER IDLER ROLLER	1
5	1711596	607040561	PULL ROLLER	2
6	1711597	701050240	BEARING FLANGE	4
7	1711598	613040131	PULL ROLLER BUSHING	4
8	1711613	703010332	HEATER HOLDER	4
9	1711649	601310501	HEATER HOLDER BRACKET	2
10	1711649	601310501	HEATER HOLDER BRACKET	1
11	1711607	701050161	BEARING	2
12	1711599	603030538	PULL ROLL TENSION BOLT	2
13	1711600	601310509	TENSION LEVER FOR PULL ROLLS	2
14	1711610	601310503	RIGHT INFRARED HEATER SUPPORT	2
15	1712606	701080271	SPROCKET	1
16	1712575	603030542	IDLER ROLLER CENTERED PIN	2
17	1711601	701090157	PULL ROLLER TENSION SPRING	2
18	1711602	603030539	PULL ROLL CENTER PIN	2
19 & 20	1711647	607040556	UPPER & LOWER HEAT TUBE	1EA.
21	1711618	701090115	COMPRESSION COIL SPRING	2
22	1712095	701050234	BEARING FLANGE	1
23	1711603	701090718	GRIP RING	2
24	1711609	603030162	LOWER IDLE ROLLER	1
25	1711555	603030151	SUPPORT BAR	1
26	1711648	706025028	INFRARED HEATER	2
	1722775	1722775	INFRARED HEATER SCREW (NOT SHOWN)	4
27	1711604	604037011	HEAT TUBE BEARING HOUSING	2
28	1711605	701020209	NEEDLE ROLLER BEARING	4
29	1720618	701100311	SCREW (SUPPORT BAR)	1
30	1711651	704150107	THERMAL CUT-OFF (T.C.O.)	1
31	1712129	701106603	SET SCREW	2
32	1711569	701107316	ROLLER BOLT, SOCKET HEAD HEX	2
	701108106	701108106	INFRARED HEATER BOLT (NOT SHOWN)	4
	703050205	703050205	OUTER CERAMIC (NOT SHOWN)	4
	703050210	703050210	INNER CERAMIC (NOT SHOWN)	4
	704161716	704161716	HEATER JUMPER WIRE (NOT SHOWN)	2

## 8.1.7 CONTROL PANEL ASSEMBLY

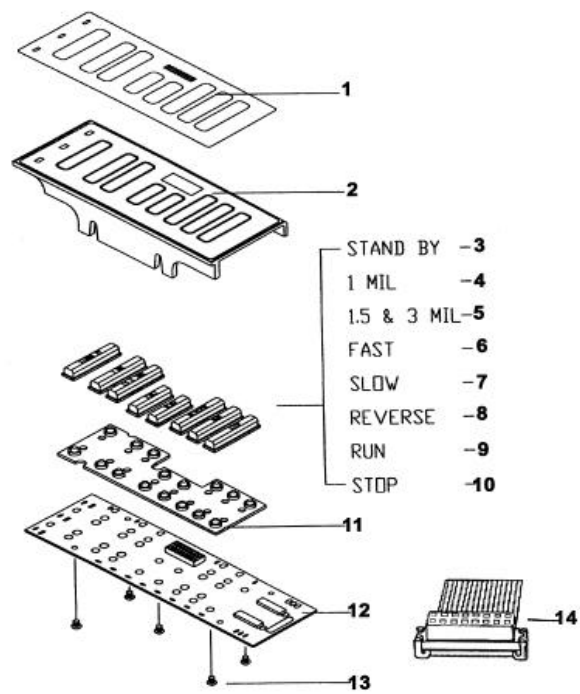

## 8.1.7 CONTROL PANEL ASSEMBLY

<b>ITEM#</b>	<b>GBC#</b>	<b>GMP#</b>	<b>DESCRIPTION</b>	<b>QTY</b>
1	1711645	<b>802104002</b>	CONTROL PANEL STICKER	1
2	1711646	<b>703020221</b>	PLASTIC SWITCH PANEL	1
3	N/A	<b>703020501</b>	CONTROL KEY, STAND BY, YELLOW	1
4	N/A	<b>703020502</b>	CONTROL KEY, 1 MIL, GREEN	1
5	N/A	<b>703020503</b>	CONTROL KEY, 1.5 & 3 MIL, GREEN	1
6	N/A	<b>703020504</b>	CONTROL KEY, FAST, BLACK	1
7	N/A	<b>703020505</b>	CONTROL KEY, SLOW, BLACK	1
8	N/A	<b>703020506</b>	CONTROL KEY, REVERSE, BLACK	1
9	N/A	<b>703020507</b>	CONTROL KEY, RUN, GREEN	1
10	N/A	<b>703020508</b>	CONTROL KEY, STOP, BLACK	1
11	1711655	<b>704090313</b>	SWITCH MEMBRANE (RUBBER)	1
12	1711656	<b>706011113</b>	CONTROL PANEL PCB ASSY.	1
13	1711641	<b>701104803</b>	SCREW	1
14	1711659	<b>704161717</b>	CONTROL PANEL CABLE (8 PIN)	1

**(USE GMP PART NUMBERS WHEN ORDERING PARTS)**

## 8.1.8 SAFETY LEVER ASSEMBLY

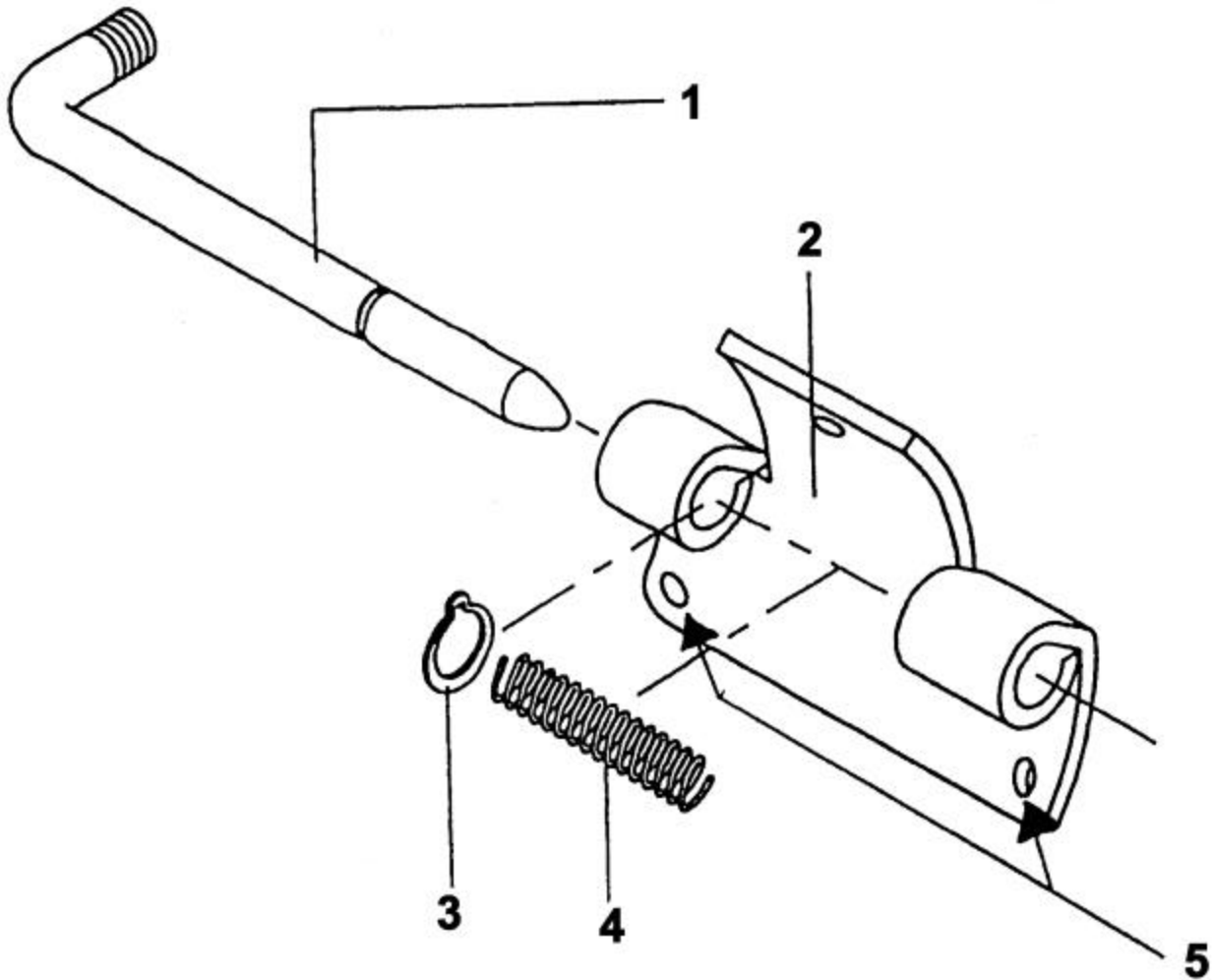

ITEM#	GBC#	GMP#	DESCRIPTION	QTY
1	1712074	613030613	LEVER FOR FRONT TABLE	1
2	1711638	601310511	LEVER GUIDE FOR FRONT TABLE	1
3	1711636	701090721	RETAINING RING	1
4	1712612	701090160	COMPRESSION COIL SPRING	1
5	1911303	1911303	MOUNTING SCREWS (NOT SHOWN)	2

(USE GMP PART NUMBERS WHEN ORDERING PARTS)

## 8.1.9 CUTTER ASSEMBLY

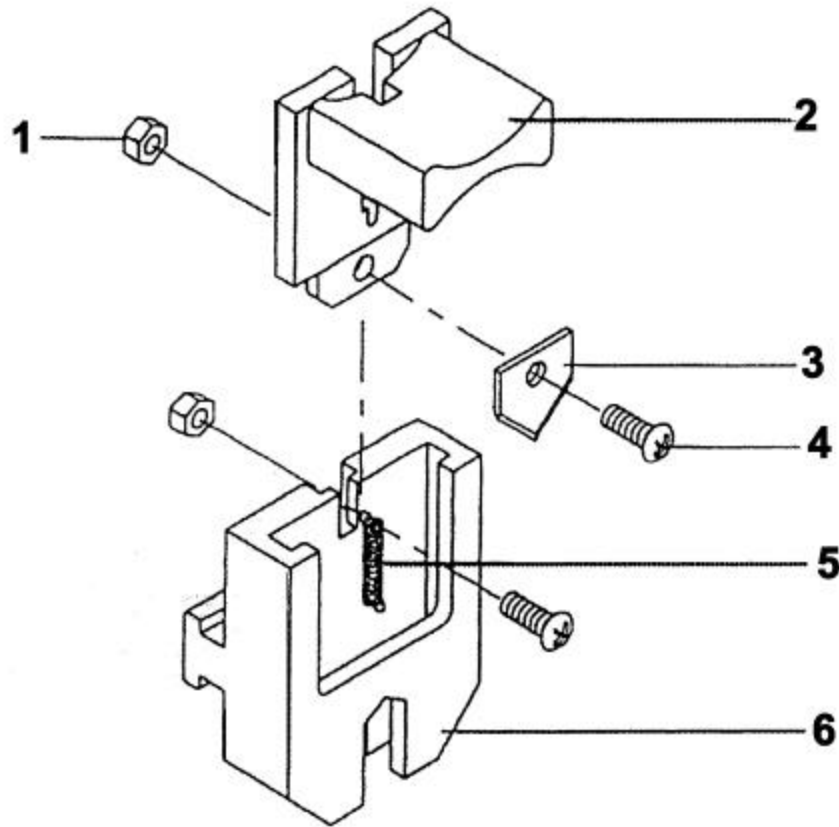

ITEM#	GBC#	GMP#	DESCRIPTION	QTY
	1711567	706111049	<b>SLITTER ASSEMBLY (1-6)</b>	1
1	1712134	701110101	NUT	2
2	1720586	604022034	SLITTER LEVER	1
3	1154019	1154019	SLITTER BLADE	1
4	1711641	701104803	SCREW	2
5	1712611	701090159	TENSION COIL SPRING	1
6	1720585	604022033	SLITTER HOUSING	1

(USE GMP PART NUMBERS WHEN ORDERING PARTS)

## 9.0 RECOMMENDED SPARE PARTS LIST

Use the suggested multipliers as a *guideline* to maintain your spare parts inventory. This multiplier is based on a *six-month's supply*. Multiply the number of machines that you will be required to service in a given territory (your machine base) by the multiplier listed. Refer to 9.1 *Explanation of Multipliers* for reference. Periodic review of your machine base is recommended. As your machine base grows, your stocking levels will also grow.

**NOTE:** This is a list of high usage parts only. Less frequently used and incidental parts should be determined and stocked at your discretion.

GBC#	GMP#	DESCRIPTION	QTY
1711647	607040556	UPPER & LOWER HEAT TUBE (ROLLERS)	0.2
1711648	706025028	INFRARED HEATERS	0.2
1711652	706040202	HEAT SENSOR (THERMO-COUPLE)	0.2
1711651	704150107	THERMAL CUT-OFF (T.C.O.)	0.2
1711650	706011116	MAIN P.C. BOARD 115 VOLT	0.2
1711656	706011113	CONTROL PANEL P.C. BOARD	0.1
1711655	704090313	CONTROL PANEL MEMBRANE	0.04
1711554	07050703	TRIAC	0.2
1711588	704091031	15 AMP CIRCUIT BREAKER	0.2
1720524	609020200	DC MOTOR	0.04
1711570	604037021	1" CORE ADAPTOR	0.1
1720571	613030527	THUMB SCREW FOR CORE ADAPTER	0.1
1712140	703070101	BRAKE PAD	0.1
1711567	706111049	CUTTER ASSEMBLY	0.04

## 9.1 EXPANATION OF MULTIPLIERS

MULTIPLIER	MACHINE POPULATION
1	Keep <b>one</b> of these parts for every <b>one</b> unit in your territory
0.2	Keep <b>one</b> of these parts for every <b>five</b> units in your territory
0.1	Keep <b>one</b> of these units for every <b>ten</b> units in your territory
0.04	Keep <b>one</b> of these units for every <b>twenty five</b> units in your territory
0.02	Keep <b>one</b> of these units for every <b>fifty units</b> in your territory
0.01	Keep <b>one</b> of these units for every <b>one hundred</b> units in your territory

## **10.0 ADDITIONAL INFORMATION**

This section contains information released after the manual was published. All information pertinent to this unit should be inserted in this section whether it is published in a National Service Bulletin or obtained from any other source.

GBC National Service Department  
500 Bond Street  
Lincolnshire, IL 60069  
(800) 790-7787

## NATION SERVICE BULLETIN

TO: SEE DISTRIBUTION  
FROM: NATIONAL SERVICE DEPARTMENT  
SUBJECT: **ULTIMA 65 TRIAC TEST AND  
ROLLER PRESSURE ADJUSTMENT**

N.S.B. NO: 210D

Page: 1 of 1

Date: 09/07/98

### **TRIAC TESTING:**

When testing the Triac it must be tested out of the circuit and at room temperature. Use an Ohm meter to take the readings between the leads as follows.

RED & YELLOW = OPEN  
BLUE & YELLOW = OPEN  
RED & BLUE = CLOSED

### **ROLLER PRESSURE ADJUSTMENT:**

When adjusting the roller pressure on the Ultima - 65, keep in mind that the adjustments must be the same on both sides left to right as follows.

FRONT ROLLERS = the setscrew must be flush with the block.

REAR ROLLERS = leave 4-5 threads showing above the blocks (approx. 6 mm)

JMH



National Service Department  
6210 Capitol Drive  
Wheeling, IL 60090  
847/541-4477

## NATIONAL SERVICE BULLETIN

TO: SEE DISTRIBUTION  
FROM: NATIONAL SERVICE DEPARTMENT  
SUBJECT: **Ultima65 & Eagle Series Laminators  
Helpful Hints Bulletin**

N.S.B. NO: 210H

Page: 1 of 4

Date: 10/15/98

The following is a copy of the **September 1997 issue, vol. 1, EAGLE EYE TECHNICAL INFORMATION** bulletin published by the Color Finishing Division. It offers excellent information and procedures for determining problems associated with GBC's new Color Finishing Laminators. Please review and add this NSB to your Ultima65 and Eagle Series Service Manuals.

***EAGLE EYE TECHNICAL INFORMATION, September-1997, vol. 1***

### IN THE BEGINNING

GBC's evolution in the laminators has taken the knowledge of lamination to a higher level than ever before. The new GBC Color Finishing Laminators have distinctive characteristics that their older predecessors did not have. With the flexibility to use a wide range of thermal and cold Pressure Sensitive Adhesive (PSA) films, the word lamination takes on new meanings.

Learning the difference between machine malfunction and laminating the different types of printing in today's market will test your knowledge of lamination and troubleshooting problems. Before assuming the machine to be at fault, ask a few questions to determine "what's wrong with this picture".

### SEEING THE PROBLEM

- \* Wrinkling at the edges.
- \* Excessive wrinkling between two separate laminated sheets running parallel to each other.
- \* Air bubbles in the lamination.
- \* Edge of lamination not sealed.
- \* Warping of product after lamination.
- \* Cracking of the printed material after lamination.
- \* "Silvering" on the laminated product.
- \* Creasing in various areas of the laminated product.

The previous mentioned conditions are not necessarily caused by machine malfunction. The following are examples of some conditions that may influence the quality of lamination.

Media being laminated - Some prints are made using synthetic materials. This material usually exhibits waves or wrinkles when laminated with thermal films. Pressure Sensitive Adhesive (PSA) films are best suited for this application. Thickness of product plays an important part in the laminator's ability to seal at the edge. As the thickness of the material increases, the chance of achieving a sealed edge decreases.

Too little or too much heat or roller pressure - Excessive heat usually causes waves or warping of the finished product. Heat problems may also appear in the form of air bubbles. "Silvering" is a condition usually caused by insufficient heat. It is mostly noticeable in dark colors. Silvering may also be noticed when laminating with PSA films, which take approximately 24 hours to cure. If the heat is at the recommended temperature for both the film and the product and bubbles, waves, or creasing are still present, this could be caused by differences in roller pressure, front to back or left to right.

Differences in film manufacturing - The preset temperatures for the GBC Eagle are set for GBC NAP-II laminating film, using 20 lb. Bond paper. GBC Eagle laminators usually will laminate a variety of different manufacturer's film. When laminating with films other than NAP-II, adjustments to the preset temperatures and speed may be necessary.

Ink and toner coverage - Wide format and color prints are made in a variety of ways. The common trend is to use alcohol based inks, called GA ink, or oil based inks, called GO ink. The GA inks usually work very well with thermal films. The GO inks are sensitive designed for vinyl substrates. Another ink type is PIEZO, which is wax based and comes in a "stick" form; it may crack if folded or rolled tightly. Pressure Sensitive Adhesive (PSA) films are great candidates for these applications.

**Ink and toner coverage (continued)** - Dry toner is commonly used in most copiers and printers in today's market. Some copiers/printers use water-soluble toner, while others like XEROX use fuser oil to fix the image to the paper. Fuser oil may not allow conventional laminating film to adhere to the paper. In most cases, GBC thermal HI-TAC film solves the problems of excessive fuser oil.

### **ROLLER PRESSURE BY THE FOOTPRINT**

A laminator's footprint can visually provide a quick assessment of roller pressure. The footprint is the impression made by the heat rollers when the film is allowed to sit idle for three minutes or longer. For best results, use 1.5mil film for this procedure. Run approximately 3 feet of clear film through the heated laminator. Wait approximately 3 minutes for the footprint to form. Run another 3 feet of film and examine the impression. The footprint should be even on both sides and slightly thicker at the center. If this is achieved, run newspaper or lightweight paper through the laminator and check for lamination quality.

**Paper Pull Setup Test** - This test can be performed to correct roller balance problems. The test must be performed after removing or replacing rollers.

1. Remove all laminating film from front and rear rollers.
2. Cut several 1-inch strips of regular 20lb Bond paper.
3. Gap the rollers and insert the strips starting the test with front heat rollers first. Place the strips at an equal distance, left, center, and right.
4. Apply full pressure to the rollers and lock the rollers in place.
5. Holding the strip at the end, centered, try to pull the paper out of the nip point at each area.
6. If the paper can be pulled from any of these points, additional pressure should be added to the right or left side to increase the pressure at the specific location. The center pressure is affected by adjusting the right and left sides of the rollers. A recommended one full turn should be made to the side where the paper slips.
7. Perform the same procedure for the rear rollers.

### **LAMINATION PERFORMANCE TEST**

After adjusting the roller pressure to the previously recommended starting point, install 1.5 mil film on the laminator, set the temperature to the proper setting, and allow the heat to rise until ready.

Before making any further adjustments, please check the laminated footprint again for the previously stated dimensions. If further adjustment is needed, perform the adjustment with equal full turns at the adjustment point.

### **EAGLE ROLLER REPLACEMENT**

When replacing the rollers, the pressure set up adjustment on the Eagle laminator is crucial to the quality of lamination. This adjustment must be made to the front and rear rollers because the roller brackets support both sets of rollers.

#### **Removing The Rollers**

1. Disconnect power to the machine.
2. Release pressure on rollers.
3. Remove feed table, left side - film tension knobs, right side pressure handle, and both right and left side covers.

4. Disconnect heat coil wires attached to ceramic end of the heater tube. The heater tube is inside of the heat roller.
5. Disconnect thermal cutout (TCO) wires attached to the TCO by spade terminals.
6. Remove top and bottom green silicone heater holders (one side only).
7. Remove glass heat coil tubes out of opened side and store in a safe area to prevent breakage.
8. Remove roller pressure screws and springs.
9. Remove Phillips head screws securing heat coil holders brackets, right and left.
10. Loosen Allen screws on the motor gear. Slide gear outward and away from idler gear.
11. Remove screws securing the idler gear bracket. Lift away from machine along the drive chain.
12. Loosen Allen screws on chain sprockets attached to the lower heat and pull rollers and remove from the roller shaft.
13. Remove all snap rings securing the rollers, both right and left.
14. Remove remaining bracket supports.
15. Slide rollers out of the open side.

***To reassemble, follow the previous steps in reverse.***

**Roller Adjustment** - After replacing heat or pull rollers, run the machine, with full pressure, to settle the rollers to a home position. The spring pressure on the rollers should be adjusted to a starting point.

***To begin:***

1. Lower the pressure screws flush with the threaded end of the eccentric bracket.
2. Make 7 full turns on each of the four front heat roller tension screws.
3. Make 2 full turns on each of the four rear pressure roller tension screws.

After making the roller adjustments, apply full pressure to the rollers and run the machine empty allowing components to find a home position. Follow the previously stated "Paper Pull" test and "Footprint" evaluation.

### **ULTIMA65 NOTES**

We have received several instances of the Ultima65 being too hot or too cold. Remember, the reset temperature and speed are set for use with 20lb. Bond paper. The heat temperatures are set for 1 mil "Ultima" NAP-II film and the 1.5 & 3 mil setting is for NAP-I film. There is about a 30° F temperature variance between NAP-I and NAP-II films. Make sure the correct film is used for the correct setting.

Another heat related problem that can be often diagnosed as machine malfunction is the use of heavier paper stocks. These materials deplete the preset temperature of the heat rollers or may not bond as expected.

Adjustments to the speed may be necessary to achieve acceptable results. If you do not achieve the desired results, a quick check of the PCB calibration, and adjustment (if needed) may solve the problem.

### **CARING FOR YOUR LAMINATOR**

The new breed of Eagle and Utima laminators use a softer silicone roller. This type of roller provides for a better-sealed edge. When cleaning these rollers, it is recommended that nonabrasive materials be used. ScotchBrite or eraser type belt cleaners work the best. At the present time we do not have a chemical that is safe for cleaning purposes. Under no circumstances should sandscreen be used to clean the rollers.



National Service  
500 Bond Street  
Lincolnshire, IL 60069  
800-790-7787

## NATIONAL SERVICE BULLETIN

TO: SEE DISTRIBUTION

N.S.B. NO: 210K

FROM: NATIONAL SERVICE DEPARTMENT

Page: 1 of 1

SUBJECT: **ULTIMAS & EAGLES INSTALLATION**

Date: 2/28/00

Installation of Eagles and Ultima machines should include removing the side panels and checking for any loose screws and/or connections, particularly on the P.C. Boards. This should also be a standard procedure when performing service on any of these models.



National Service  
500 Bond Street  
Lincolnshire, IL 60069  
800-790-7787

## NATIONAL SERVICE BULLETIN

TO: SEE DISTRIBUTION

N.S.B. NO: 248A

FROM: NATIONAL SERVICE DEPARTMENT

Page: 1 of 1

SUBJECT: **ULTIMA 65 UPGRADE**

Date: 5/15/00

This N.S.B obsoletes N.S.B 248, dated 5/15/00

Ultima 65's with heat problems (**gray roller machines**) will no longer be traded in. The parts the technician will need to order to bring the Ulitma 65 to current specs are listed below. Part Number **1722626** has been assigned to the upgrade kit. This upgrade kit should only be ordered for **gray roller machines when "overheat" symptoms occur**. The technician must then **close the call as a 02 warranty using the kit part number**.

Part #	Description	Qty
1711647	Heat Roller	2
1711648	Infrared heater	2
1711650	Main PCB	1
1711656	Control PCB	1
1711655	Control Panel Membrane	1
1711649	Heater Holder Bracket (Top)	2
1711652	Heat Sensor	1



National Service Department  
500 Bond St.  
Lincolnshire, IL. 60069

## NATIONAL SERVICE BULLETIN

TO: SEE DISTRIBUTION

N.S.B. NO: 243C

FROM: NATIONAL SERVICE DEPARTMENT

Page: 1 of 1

SUBJECT: **GMP LAMINATION CALIBRATION FIXTURES**

Date: 05/09/01

GBC Service Parts Dept is currently stocking the Calibration Fixture part number 1700407. Once the inventory has been depleted, the Service Parts Dept will be stocking a new Universal Type "A" Calibration Fixture. This Calibration Fixture part number 706111164 can be used on all current GMP Laminators, including the Pouch Laminators. **However the Type "A" Calibration Fixture will not work with the TITAN 165/110.** The TITAN 165/110 Calibration Fixture Type "B" can be ordered under part number **706111165, and is only to be used on the TITAN 165/110.**



Professional Support Services  
500 Bond St.  
Lincolnshire, IL. 60069

## NATIONAL SERVICE BULLETIN

TO: SEE DISTRIBUTION

N.S.B. NO: 210P

FROM: NATIONAL SERVICE DEPARTMENT

Page: 1 of 1

SUBJECT: **ULTIMA-65 INFRARED HEATER ASSEMBLY**

Date: 02/11/02

This NSB supersedes and obsoletes NSB 210N, dated 4/25/01.

Listed below are the individual components for the Ultima-65 Infrared Heater Assembly.

<b>PART NO.</b>	<b>DESCRIPTION</b>
701110504	Glass Tube Cap
701108106	Heater Wire Holding Bolt
703050210	Inside Ceramic Insulator
703010309	Silicone Washer
703050205	Outside Ceramic Insulator
6130422	Hexagon Nut

R.P.

10-10





Professional Support Services  
500 Bond St.  
Lincolnshire, IL. 60069

## NATIONAL SERVICE BULLETIN

TO: SEE DISTRIBUTION N.S.B. NO: 210Q  
FROM: NATIONAL SERVICE DEPARTMENT Page: 1 of 1  
SUBJECT: **ULTIMA-65 TURNING OFF WHILE RUNNING** Date: 6/21/02

When you encounter an Ultima-65 turning off while running, here are some things that you should know:

- The Laminator must be plugged into a dedicated grounded outlet. Do not connect other equipment to the same circuit.
- Overloading the motor will cause the Transformer's TCO to blow. The Transformer does not have a resettable thermal cut off (TCO), so you will have to replace the Transformer.
- There is a resettable fusible link on the Main P.C. Board that replaced the original 3-amp fuse. When the Main P.C. Board gets overloaded (hot), the machine will turn off. Once it cools down, you can start running the machine again.

There are a number of variables that will cause the machine to turn off while running; here is what to check for:

- The 15 Amp Circuit Breaker may have tripped. If you have to reset the Circuit Breaker several times in a short period of time, the Breaker may have become weak and must be replaced with part number 704091031.
- Check Safety Shield and Feed Table Tray Interlock switches and connections.
- Make sure product thickness does not exceed the maximum of 1/16" (1.59mm).
- Too much Brake Tension on Film Shafts. As recommended, use the minimum amount of tension to eliminate wrinkles in the finished item.
- Check for proper pressure/tension between upper and lower Heat Tubes (Rollers) and upper and lower Pull Rollers. The pressure applied should be enough to enable the rollers to pull the film and product being laminated through, however, it should not be so great that it causes marks on the film or product.
- Motor/Sprocket Chain is too tight. Chain must have some play/slack in it.



Professional Support Services  
500 Bond St.  
Lincolnshire, IL. 60069

## NATIONAL SERVICE BULLETIN

TO: SEE DISTRIBUTION

N.S.B. NO: 210R

FROM: NATIONAL SERVICE DEPARTMENT

Page: 1 of 1

SUBJECT: **ULTIMA 65 & EAGLE 35, 65, AND 105  
HEATER JUMPER WIRES W/CONNECTORES**

Date: 07/18/02

Part number 704161716 is for the Ultima 65 Heater Jumper Wires with Eyelet Connectors. Part number 704161803 is for the Eagle 35, 65, 105 Heater Jumper Wires. These wires connect to the ceramic ends of the infrared heaters. Please update your Service Manual with this information.

**NOTE:** Parts are on order and should be in stock within 6 to 8 weeks.

